

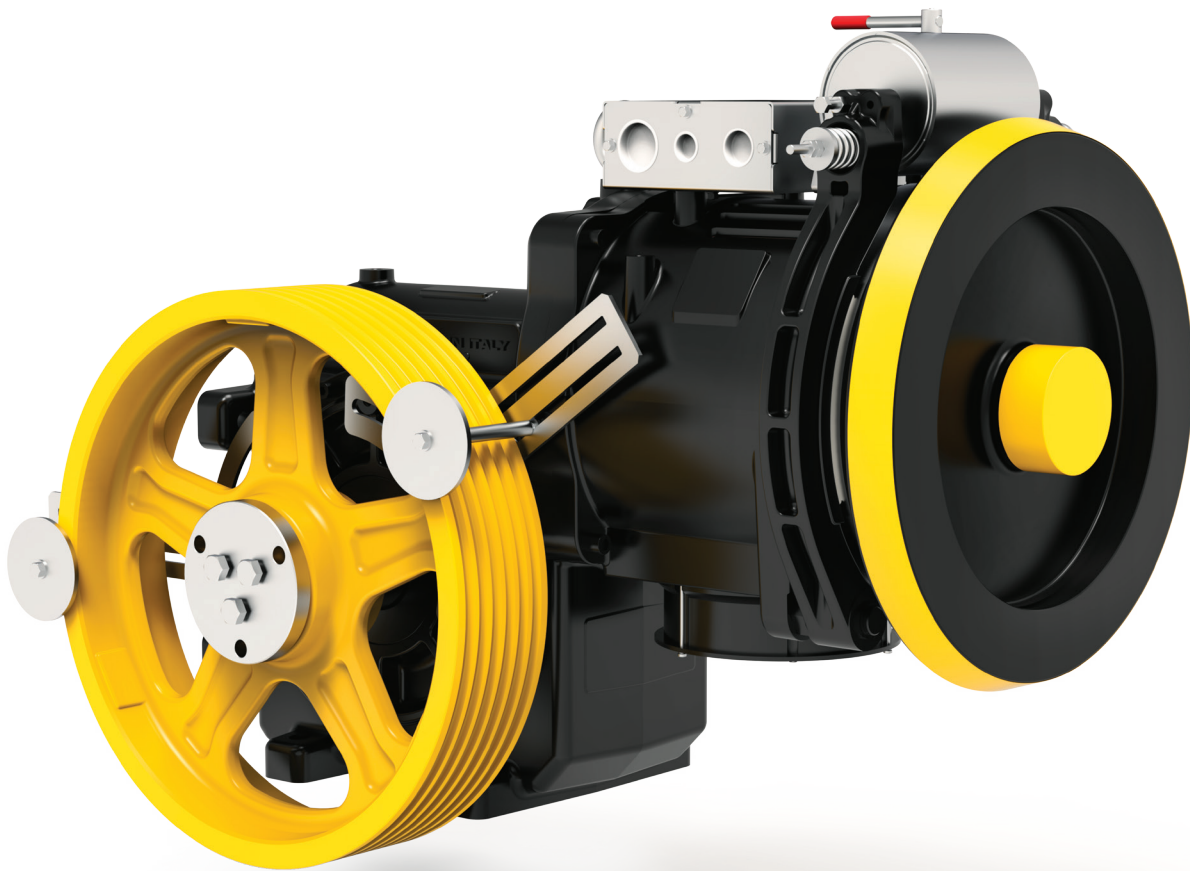

SH160

GEARED MACHINES



Model	For rated loads up to	Speed range synchronous	Traction sheaves diameter		Max Static Load	Carico statico Max
	[kg]	50Hz [m/s]	60Hz [m/s]		[mm]	[kN-kg]
SH160 	1250	0,43 ... 4,02	0,51 ... 4,83		450,520,560,600,650,700	42,2 - 4300
SH160LS 	1250	0,43 ... 4,02	0,51 ... 4,83		450,520,560,600,650,700	42,2 - 4300

Roping 1 : 1



GEARED SH160

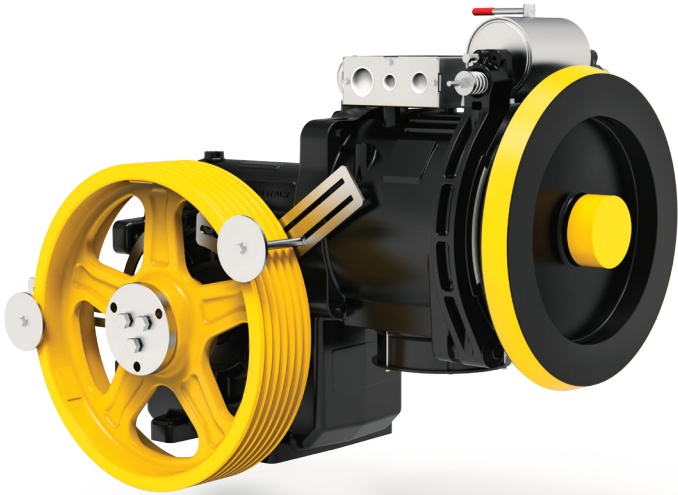

Maximum Static Load SH160	42,2 kN - 4300 kg
Power Range 50 Hz 4 poles VVVF	7,5 ÷ 20 kW
Power Range 50 Hz 4/16 poles	7,5 ÷ 11 kW
Power Range 50 Hz 6 poles VVVF	7,5 ÷ 11 kW
Power Range 50 Hz 6/16 poles	5,1 ÷ 7,5 kW
Power Range 60 Hz 4 poles VVVF	8,2 ÷ 18 kW
Power Range 60 Hz 4/16 poles	8,2 ÷ 12 kW
Power Range 60 Hz 6 poles VVVF	8,2 ÷ 12 kW
Power Range 60 Hz 6/16 poles	5,5 ÷ 8,2 kW
Riduction	1/55; 1/43; 1/35; 2/53; 2/43; 3/41
Weight	450 kg
Oil capacity	9 l
Geared machine Rh o Lh (see from motor)	Picture Gear Lh

The geared machine efficiency values are present above each "rated load" table
The motor efficiency values are present in the table "electric motor data"

DIMENSIONS

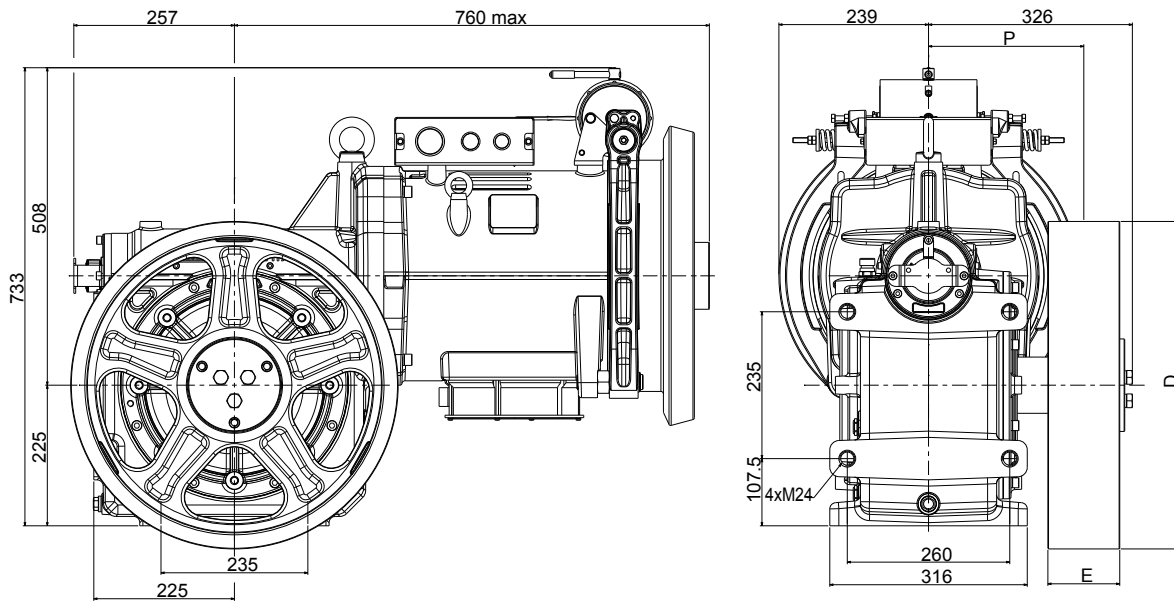

Wrapping System	Traction sheave		Dimension	Load*)	Static Load Direction
	D [mm]	E [mm]			
CSW	450	115	248,5	42,2 - 4300	
	520				
	560				
	600				
	650				
	700				

*) Max. static load on the slow shaft CSW: Conventional single wrap ESW: Extended single wrap

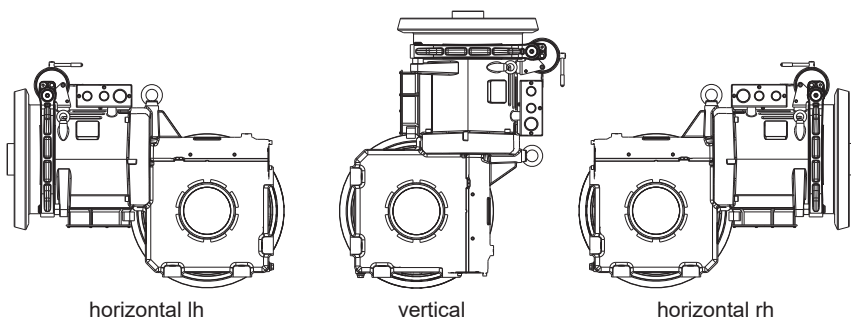

Brake Electromagnet		
[V]	[A]	[W]
24	9,71	233
48	4,85	233
60	3,96	238
80	2,70	216
110	1,83	201
200	1,05	210

		50Hz							60Hz						
		VVVF 1500 rpm 4 Poles AC2 1500/375 rpm 4/16 Poles							VVVF 1800 rpm 4 Poles AC2 1800/450 rpm 4/16 Poles						
		Motor Output [kW]													
		VVVF AC2 7,5	VVVF AC2 9	VVVF AC2 11	VVVF 13,5	VVVF 16,5	VVVF 20		VVVF AC2 8,2	VVVF AC2 10	VVVF AC2 12	VVVF 15	VVVF 18		
R.R.	Traction Sheave Ø	Speed syn.	Max Rated Load						Speed syn.	Max Rated Load					
[i]	[mm]	[m/s]	[kg]	[kg]	[kg]	[kg]	[kg]	[kg]	[m/s]	[kg]	[kg]	[kg]	[kg]	[kg]	
1/55	450	0,64	1250	--	--	--	--	--	0,77	1250	--	--	--	--	
1/55	520	0,74	1200	1220	--	--	--	--	0,89	1085	1160	--	--	--	
1/55	560	0,80	1115	1135	--	--	--	--	0,96	1005	1075	--	--	--	
1/43	450	0,82	1110	1250	--	--	--	--	0,99	1000	1245	1250	--	--	
1/55	600	0,86	1040	1060	--	--	--	--	1,03	940	1005	--	--	--	
1/55	650	0,93	960	975	--	--	--	--	1,11	865	925	--	--	--	
1/43	520	0,95	960	1175	1250	--	--	--	1,14	865	1080	1250	--	--	
1/55	700	1,00	890	905	--	--	--	--	1,20	805	860	--	--	--	
1/35	450	1,01	920	1130	1250	--	--	--	1,21	830	1035	1250	--	--	
1/43	560	1,02	890	1090	1250	--	--	--	1,23	800	1000	1220	1250	--	
1/43	600	1,10	830	1015	1220	--	--	--	1,32	750	935	1140	1165	--	
1/35	520	1,17	800	975	1215	--	--	--	1,40	715	895	1095	1250	--	
1/43	650	1,19	765	940	1125	--	--	--	1,42	690	860	1050	1075	--	
1/35	560	1,26	740	905	1125	1250	--	--	1,51	665	830	1015	1250	--	
1/43	700	1,28	710	870	1045	--	--	--	1,53	640	800	975	1000	--	
2/53	450	1,33	725	885	1100	1250	--	--	1,60	655	815	990	1250	--	
1/35	600	1,35	690	845	1050	1165	--	--	1,62	620	775	945	1165	--	
1/35	650	1,46	640	780	970	1075	--	--	1,75	575	715	875	1075	--	
2/53	520	1,54	625	765	950	1160	--	--	1,85	565	705	860	1090	1095	
1/35	700	1,57	590	725	900	1000	--	--	1,88	530	665	810	1000	--	
2/43	450	1,64	595	725	905	1125	1250	--	1,97	535	665	815	1035	1250	
2/53	560	1,66	580	710	885	1075	--	--	1,99	525	655	795	1010	1015	
2/53	600	1,78	545	665	825	1005	--	--	2,13	490	610	745	945	950	
2/43	520	1,90	515	630	780	970	1200	1220	2,28	465	575	705	895	1085	
2/53	650	1,93	500	610	760	925	--	--	2,31	450	565	685	870	875	
2/43	560	2,05	480	585	725	900	1115	1135	2,45	430	535	655	830	1005	
2/53	700	2,07	465	570	705	860	--	--	2,49	420	525	635	810	815	
2/43	600	2,19	445	545	675	840	1040	1060	2,63	400	500	610	775	940	
2/43	650	2,37	410	500	625	775	960	975	2,85	370	460	565	715	865	
2/43	700	2,56	380	465	580	720	890	905	3,07	345	430	520	665	805	
3/41	450	2,59	385	470	585	730	900	1100	3,10	345	435	530	670	815	
3/41	520	2,99	335	410	505	630	780	950	3,59	300	375	455	580	705	
3/41	560	3,22	310	380	470	585	725	885	3,86	280	345	425	540	655	
3/41	600	3,45	290	355	440	545	675	825	4,14	260	325	395	505	610	
3/41	650	3,74	265	325	405	505	625	760	4,48	240	300	365	465	565	
3/41	700	4,02	245	305	375	470	580	705	4,83	220	275	340	430	520	

		50Hz							60Hz						
		Motor Output [kW]													
		VVVF AC2 7,5	VVVF/AC2 9	VVVF AC2 11	VVVF 13,5	VVVF 16,5	VVVF 20		VVVF AC2 8,2	VVVF AC2 10	VVVF AC2 12	VVVF 15	VVVF 18		
R.R.	Max Output Torque	Geared Efficiency						Max Output Torque	Geared Efficiency						
[i]	[Nm]							[Nm]							
1/55	1950	0,77	0,78	0,79	0,80	0,81	0,82	1850	0,76	0,77	0,79	0,80	0,81		
1/43	2250	0,78	0,80	0,81	0,82	0,83	0,84	2150	0,78	0,79	0,81	0,82	0,83		
1/35	2150	0,80	0,82	0,83	0,84	0,85	0,86	2150	0,79	0,81	0,82	0,84	0,85		
2/53	1850	0,83	0,85	0,86	0,87	0,88	0,89	1750	0,83	0,84	0,85	0,87	0,88		
2/43	1950	0,84	0,86	0,87	0,88	0,89	0,90	1750	0,83	0,85	0,86	0,88	0,89		
3/41	1850	0,86	0,88	0,89	0,90	0,91	0,92	1900	0,85	0,87	0,88	0,90	0,91		

Rated load values listed in the table include the weight of the ropes.
 To know the theoretical load, subtract the weight of the ropes.
 Position Of The Geared = Top Counterweight = 50% Plant efficiency = 0,80

		50Hz						60Hz					
		VVVF 1000 rpm 6 Poles AC2 1000/375 rpm 6/16 Poles						VVVF 1200 rpm 6 Poles AC2 1200/450 rpm 6/16 Poles					
		Motor Output [kW]											
			VVVF AC2 5,0	VVVF AC2 7,5	VVVF 9	VVVF 11	VVVF 13,5		VVVF AC2 5,5	VVVF AC2 8,2	VVVF 10	VVVF 12	VVVF 15
R.R.	Traction Sheave Ø	Speed syn.	Max Rated Load					Speed syn.	Max Rated Load				
[i]	[mm]	[m/s]	[kg]	[kg]	[kg]	[kg]	[kg]	[m/s]	[kg]	[kg]	[kg]	[kg]	[kg]
1/55	450	0,43	1250	--	--	--	--	0,51	1250	--	--	--	--
1/55	520	0,50	1200	1250	--	--	--	0,59	1095	1250	--	--	--
1/55	560	0,53	1115	1250	--	--	--	0,64	1015	1250	--	--	--
1/43	450	0,55	1110	1250	--	--	--	0,66	1010	1250	--	--	--
1/55	600	0,57	1040	1165	--	--	--	0,69	945	1165	--	--	--
1/55	650	0,62	960	1075	--	--	--	0,74	875	1075	--	--	--
1/43	520	0,63	960	1250	--	--	--	0,76	875	1250	--	--	--
1/55	700	0,67	890	1000	--	--	--	0,80	810	1000	--	--	--
1/35	450	0,67	925	1250	--	--	--	0,81	840	1250	--	--	--
1/43	560	0,68	890	1250	--	--	--	0,82	810	1250	--	--	--
1/43	600	0,73	835	1250	--	--	--	0,88	755	1175	1250	--	--
1/35	520	0,78	800	1240	1250	--	--	0,93	725	1125	1250	--	--
1/43	650	0,79	770	1175	--	--	--	0,95	700	1085	1175	--	--
1/35	560	0,84	740	1155	1250	--	--	1,01	675	1045	1250	--	--
1/43	700	0,85	715	1095	--	--	--	1,02	650	1005	1095	--	--
2/53	450	0,89	725	1125	1250	--	--	1,07	660	1020	1250	--	--
1/35	600	0,90	690	1075	1250	--	--	1,08	630	975	1205	1250	--
1/35	650	0,97	640	995	1150	--	--	1,17	580	900	1115	1150	--
2/53	520	1,03	630	975	1180	1250	--	1,23	570	880	1090	1250	--
1/35	700	1,05	595	920	1070	--	--	1,26	540	835	1035	1070	--
2/43	450	1,10	595	920	1120	1250	--	1,32	540	840	1035	1250	--
2/53	560	1,11	585	900	1095	1160	--	1,33	530	820	1010	1160	--
2/53	600	1,19	545	840	1025	1085	--	1,42	495	765	945	1085	--
2/43	520	1,27	515	800	970	1200	1250	1,52	470	725	895	1085	1250
2/53	650	1,28	500	780	945	1000	--	1,54	455	705	870	1000	--
2/43	560	1,36	475	740	900	1110	1250	1,64	435	675	830	1010	1250
2/53	700	1,38	465	720	875	930	--	1,66	420	655	810	930	--
2/43	600	1,46	445	690	840	1035	1220	1,75	405	630	775	940	1190
2/43	650	1,58	410	640	775	960	1125	1,90	375	580	715	870	1095
2/43	700	1,70	380	590	720	885	1045	2,05	345	540	665	805	1020
3/41	450	1,72	385	600	730	900	1110	2,07	350	545	675	815	1030
3/41	520	1,99	335	520	630	780	965	2,39	305	470	580	705	890
3/41	560	2,15	310	480	585	725	895	2,57	280	435	540	655	825
3/41	600	2,30	290	450	545	670	830	2,76	265	410	505	610	770
3/41	650	2,49	265	415	505	620	770	2,99	245	375	465	565	715
3/41	700	2,68	250	385	470	575	710	3,22	225	350	430	525	660

		50Hz						60Hz					
		Motor Output [kW]											
			VVVF AC2 5,0	VVVF AC2 7,5	VVVF 9	VVVF 11	VVVF 13,5		VVVF AC2 5,5	VVVF AC2 8,2	VVVF 10	VVVF 12	VVVF 15
R.R.	Max Output Torque	Geared Efficiency					Max Output Torque	Geared Efficiency					
[i]	[Nm]						[Nm]						
1/55	2150	0,77	0,79	0,80	0,81	0,82	2150	0,76	0,79	0,80	0,81	0,81	
1/43	2350	0,79	0,81	0,82	0,83	0,84	2350	0,78	0,81	0,82	0,83	0,84	
1/35	2300	0,80	0,83	0,84	0,85	0,86	2300	0,80	0,83	0,84	0,85	0,86	
2/53	2000	0,83	0,86	0,87	0,88	0,89	2000	0,82	0,85	0,87	0,87	0,88	
2/43	2250	0,84	0,87	0,88	0,89	0,90	2250	0,84	0,87	0,88	0,89	0,90	
3/41	2000	0,86	0,89	0,90	0,91	0,92	2000	0,86	0,89	0,90	0,91	0,92	

50Hz										
VVVF 1500 rpm 4 Poles										
AC2 1500/375 rpm 4/16 Poles										
Asynchronous Rated Power [kW]										
		VVVF 7,5	VVVF 9,2	VVVF 11	VVVF 13,5	VVVF 16,5	VVVF 20	AC2 7,5	AC2 9	AC2 11
Motor Parameters										
Rated Voltage (star connection) ⁽¹⁾⁽³⁾	[V]	400	400	400	400	400	400	400	400	400
Frequency	[Hz]	50	50	50	50	50	50	50	50	50
Synchronous Speed	[rpm]	1500	1500	1500	1500	1500	1500	1500/375	1500/375	1500/375
Asynchronous Speed	[rpm]	1458	1460	1457	1476	1475	1477	1370/300	1370/300	1370/300
Rated Current ⁽²⁾	[A]	17,3	21,2	24,1	27,4	34,1	40,6	22/13	25/15	29/17
Rated Torque	[Nm]	50	63	72	87	107	129	52	63	77
Cos φ Power Factor	[]	0,72	0,7	0,76	0,84	0,82	0,82	0,76	0,75	0,75
Starting Current	[A]	110	133	157	168	230	304	72	102	125
Starting Torque	[Nm]	117	145	163	126	182	270	125/78	150/93	183/114
Duty Cycle	[%]	60	60	60	60	60	60	30+10	30+10	30+10
Starts per Hour	[s/h]	240	240	240	240	240	240	180	180	180
Insulation Class	[]	F	F	F	F	F	F	F	F	F
Degree of Protection IP	[]	IP21	IP21	IP21	IP21	IP21	IP21	IP21	IP21	IP21

(1) The motors are standard supplied with star connection (Y), the customer can arrange a delta connection (Δ).

(2) The indicated current values are related to 400V voltage. For current values with delta connection, multiply the values by 1,732.

(3) The standard supply voltage is suitable for 380-400V/220-230V power supplies.

The geared machine includes a fan, 1~220...240V, 50/60Hz, 0,7A.

Available on request 115V supply voltage.

The inertia value includes the high speed shaft, while the flywheel is excluded.

60Hz										
VVVF 1800 rpm 4 Poles										
AC2 1800/450 rpm 4/16 Poles										
Asynchronous Rated Power [kW]										
		VVVF 8,2	VVVF 10	VVVF 12	VVVF 15	VVVF 18	AC2 8,2	AC2 10	AC2 12	
Motor Parameters										
Rated Voltage (star connection) ⁽¹⁾⁽³⁾	[V]	400	400	400	400	400	400	400	400	400
Frequency	[Hz]	60	60	60	60	60	60	60	60	60
Synchronous Speed	[rpm]	1800	1800	1800	1800	1800	1800/450	1800/450	1800/450	1800/450
Asynchronous Speed	[rpm]	1700	1710	1748	1774	1778	1670/362	1664/373	1645/360	1645/360
Rated Current ⁽²⁾	[A]	19,2	21,5	25,5	27	35	19.2/15	22/18.4	31/18	31/18
Rated Torque	[Nm]	46	56	65	81	97	47	57	68	68
Cos φ Power Factor	[]	0,75	0,76	0,76	0,84	0,84	0,76	0,8	0,75	0,75
Starting Current	[A]	110	131	150	128	232	70	105	120	120
Starting Torque	[Nm]	105	125	163	160	164	110	147	159	159
Duty Cycle	[%]	60	60	60	60	60	30+10	30+10	30+10	30+10
Starts per Hour	[s/h]	240	240	240	240	240	180	180	180	180
Insulation Class	[]	F	F	F	F	F	F	F	F	F
Degree of Protection IP	[]	IP21	IP21	IP21	IP21	IP21	IP21	IP21	IP21	IP21

(1) The motors are standard supplied with star connection (Y), the customer can arrange a delta connection (Δ).

(2) The indicated current values are related to 400V voltage. For current values with delta connection, multiply the values by 1,732.

(3) The standard supply voltage is suitable for 380-400V/220-230V power supplies.

The geared machine includes a fan, 1~220...240V, 50/60Hz, 0,7A.

Available on request 115V supply voltage.

The inertia value includes the high speed shaft, while the flywheel is excluded.

TRACTION SHEAVES AND GROOVES NUMBER x ROPES DIAMETER

Wrapping System	Traction sheave		Max n° Grooves x D	Grooves Pitch
	D [mm]	E [mm]	n° x mm	l [mm]
CSW	450	115	7xD8	14
	450	115	6xD9	17
	450	115	6xD10	17
	450	115	6xD11	17
	520	115	7xD8	14
	520	115	6xD9	17
	520	115	6xD10	17
	520	115	6xD11	17
	520	115	5xD12	19
	520	115	5xD13	19
	560	115	7xD8	14
	560	115	6xD9	17
	560	115	6xD10	17
	560	115	6xD11	17
	560	115	5xD12	19
	560	115	5xD13	19
	560	115	4xD14	22
	600	115	7xD8	14
	600	115	6xD9	17
	600	115	6xD10	17
	600	115	6xD11	17
	600	115	5xD12	19
	600	115	5xD13	19
	600	115	4xD14	22
	600	115	4xD15	22
	650	115	7xD8	14
	650	115	6xD9	17
	650	115	6xD10	17
	650	115	6xD11	17
	650	115	5xD12	19
	650	115	5xD13	19
	650	115	4xD14	22
	650	115	4xD15	22
	650	115	4xD16	22
	700	115	7xD8	14
	700	115	6xD9	17
	700	115	6xD10	17
	700	115	6xD11	17
	700	115	5xD12	19
	700	115	5xD13	19
700	115	4xD14	22	
700	115	4xD15	22	
700	115	4xD16	22	

VCI

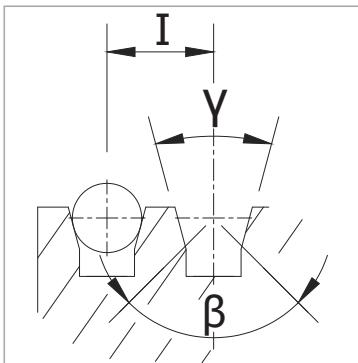

V grooves with undercut

UCI

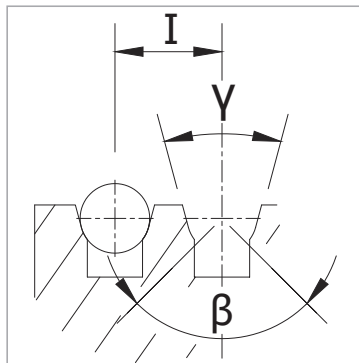

U grooves with undercut

γ = groove angle
 β = undercut angle
 I = grooves pitch

BEDPLATE SH160 | TOP MACHINE WITHOUT DIVERTING PULLEY FOR CSW WRAPPING

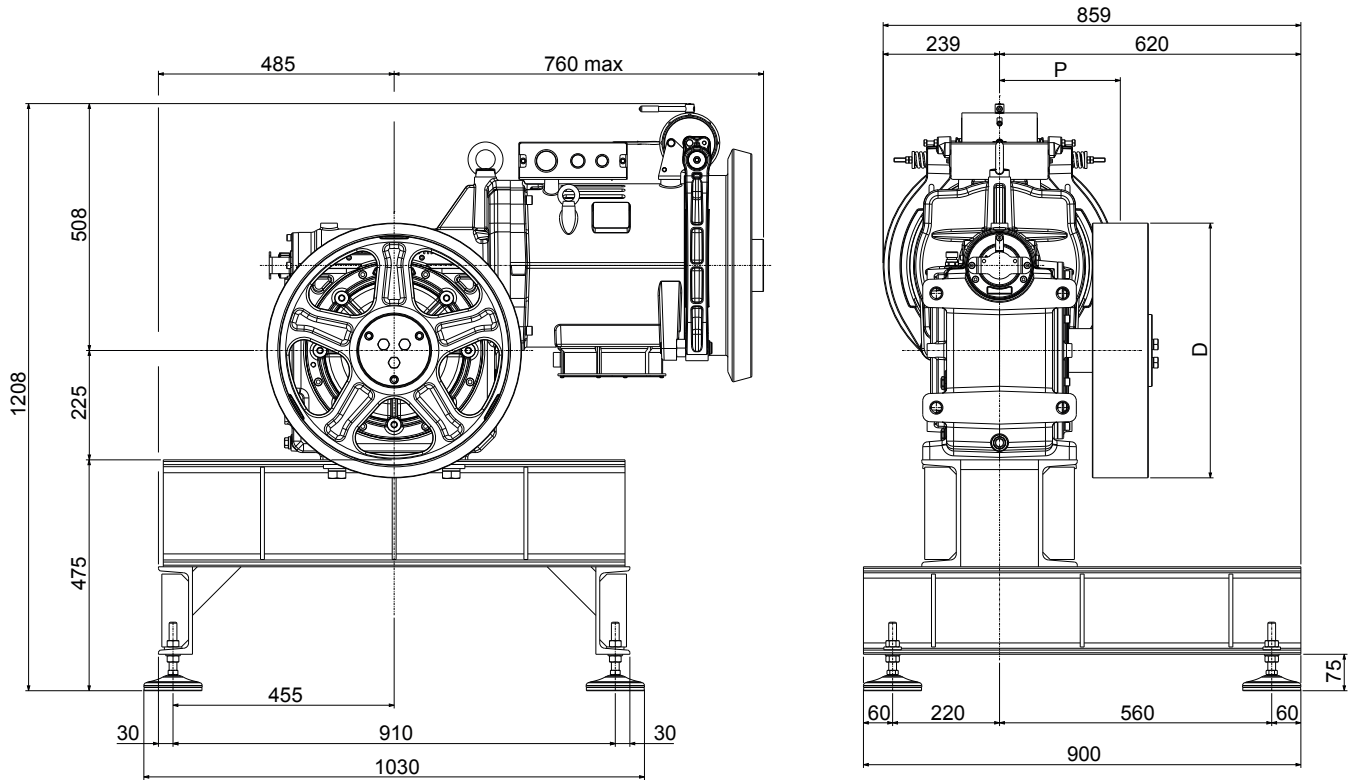

XTE1039 (D 450-700) (vibration dampers included)
 Weight of machine bedplate: 108 kg (bedplate + vibration dampers)

VIBRATIONS DAMPER SET UP

Damper code	Dimension
TAI0111	D.120x32

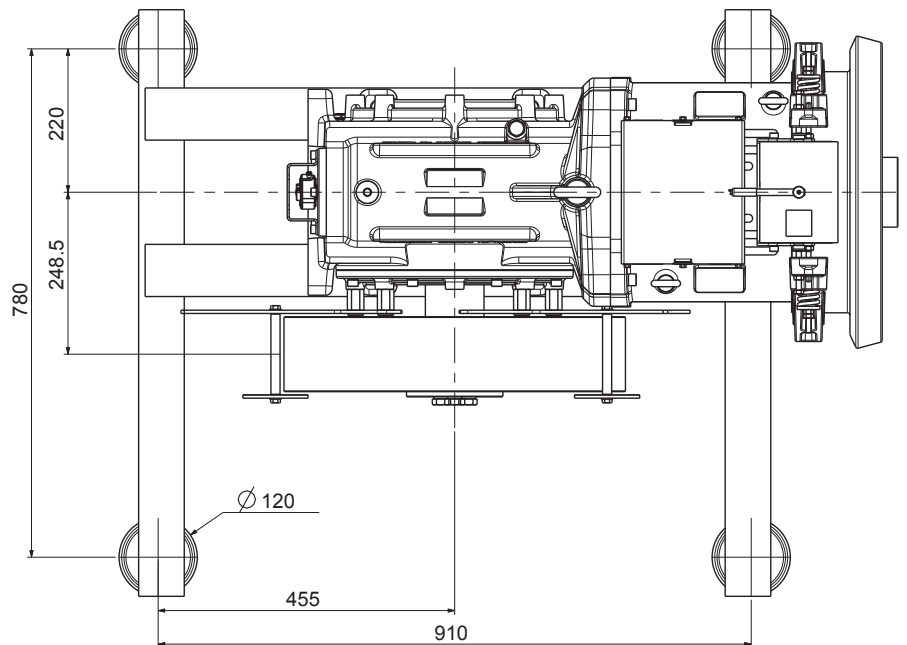

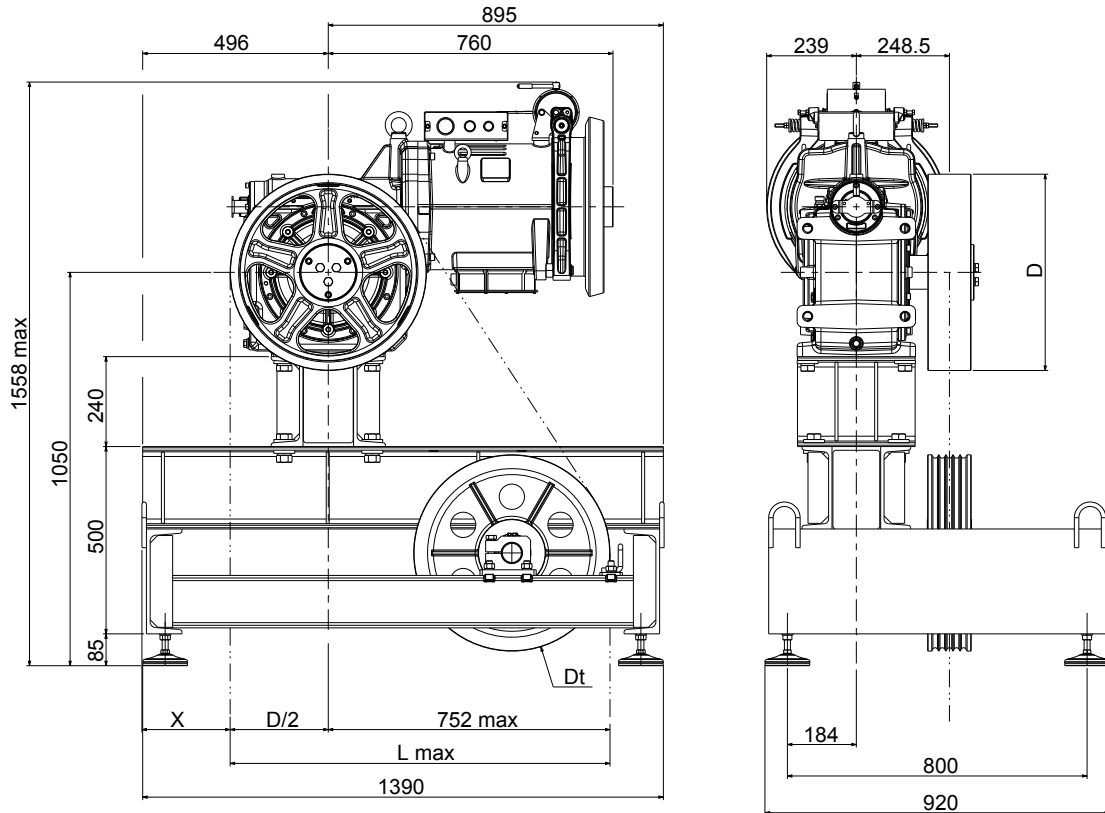

XTE1362 (Dt 400-450-520) (vibration dampers included)
 Weight of machine bedplate: 293 kg. (bedplate + diverting pulley + vibration dampers)

VIBRATIONS DAMPER SET UP

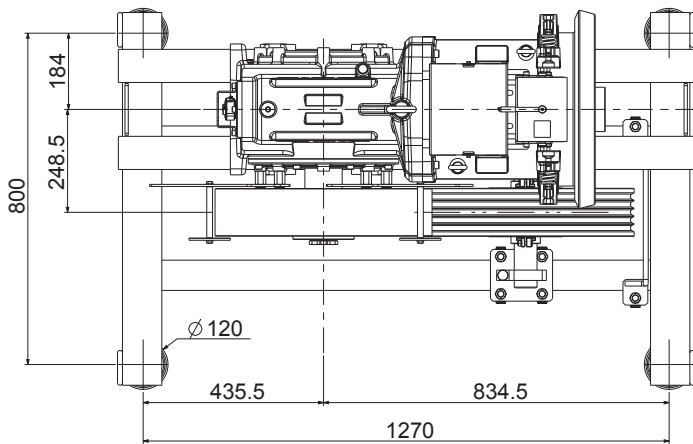

Traction Sheave	X	L Max
D [mm]	[mm]	[mm]
450	270	975
520	235	1010
560	215	1030
600	195	1050
650	170	1075
700	145	1100
600	80	1000
Damper code	Dimension	
TAI0111	[mm]	
	D.120x32	

BEDPLATE SH160 LS | BOTTOM DRIVE MACHINE WITH CSW WRAPPING

(Ropes upwards)

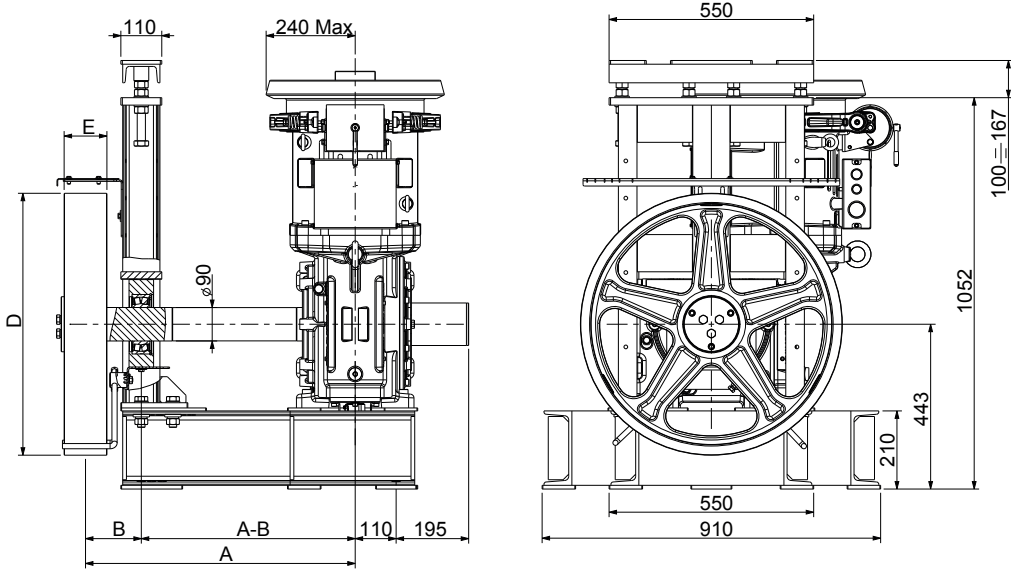

Quote "A"	Quote "B"	Static Load
[mm]	[mm]	[kg]
500	150	4300
	175	3700
	200	3200
600	150	4300
	175	3700
	200	3200
725	150	4300
	175	3700
	200	3200

INSTALLATION POSITION

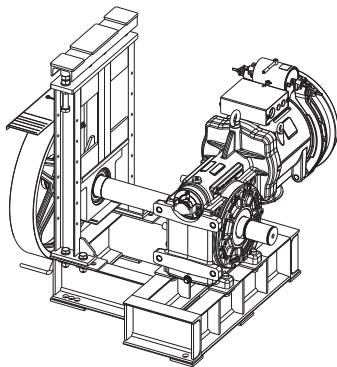

Right hand Machine

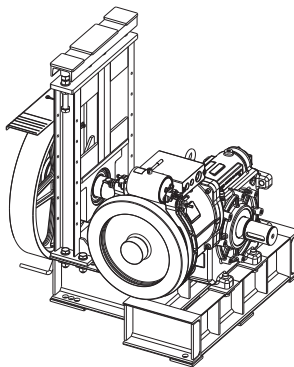

Left hand Machine

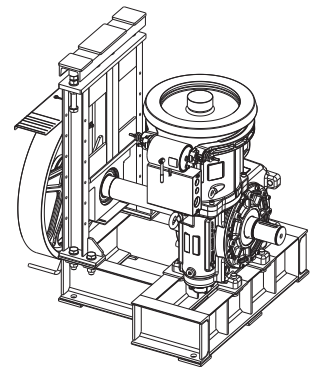

Vertical Machine

DIVERTING PULLEYS AND GROOVES NUMBER x ROPES DIAMETER

Diverting Pulley		Max n° Grooves x D	Grooves Pitch
Dt [mm]	E [mm]	n° x mm	l [mm]
400	116	7xD8	14
450	116	6xD11	17
520	116	5xD13	19

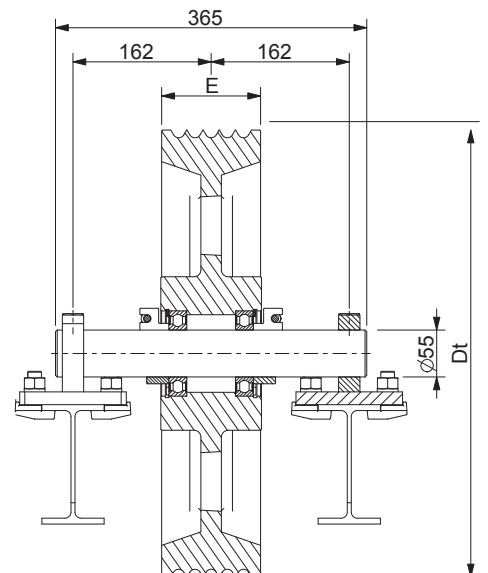
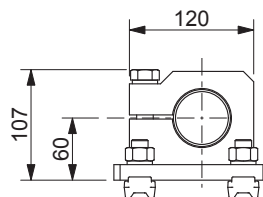



Sicor S.R.L.

Viale Caproni, 32 Rovereto (TN) - Italy • Tel: +39 0464 484 111 • info@sicoritaly.com

www.sicoritaly.com