

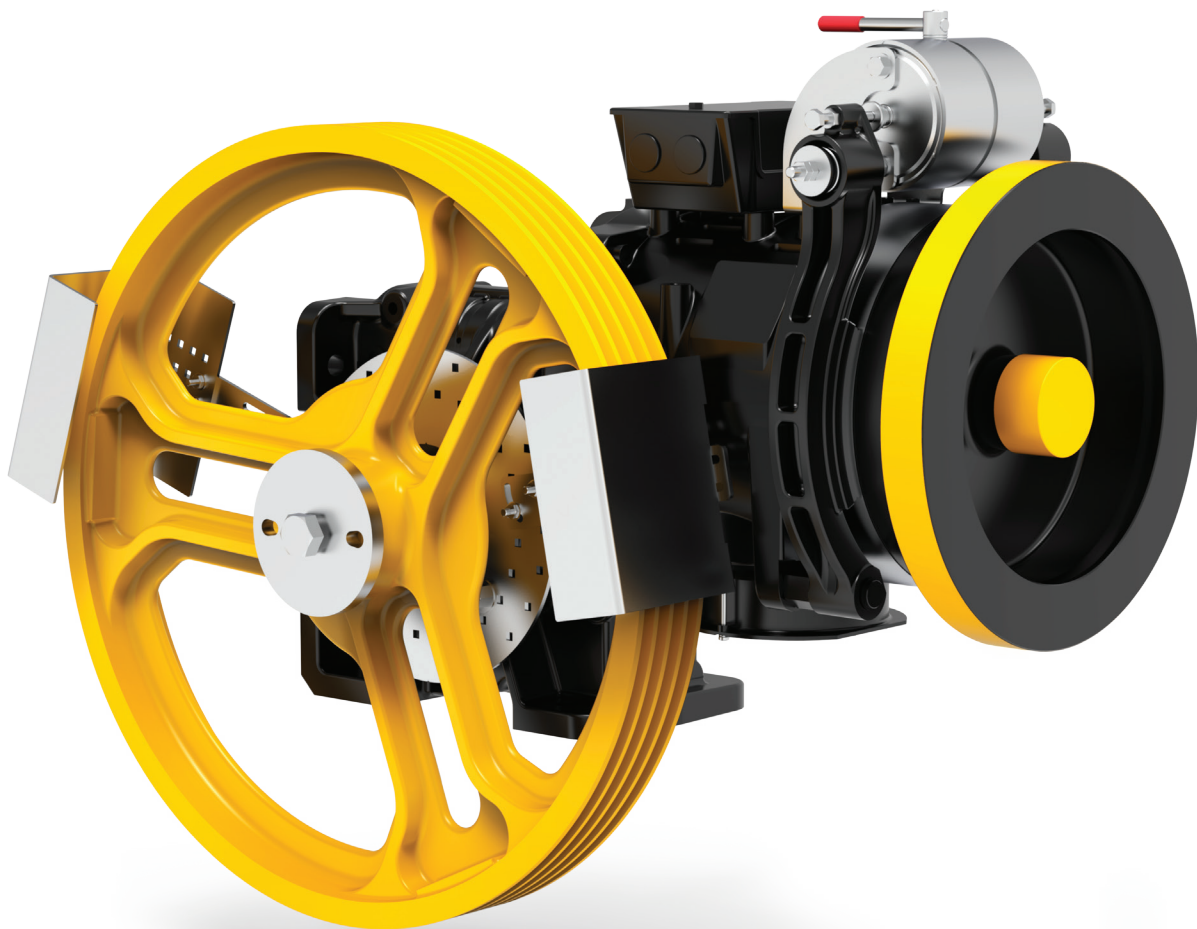

SH110B

GEARED MACHINES



Model	For rated loads up to	Speed range synchronous		Traction sheaves diameter	Max Static Load
		[kg]	50Hz [m/s]		
SH110B 	400	0,30 ... 2,19	0,37 ... 2,63	320,360,400,450,480,520,550,600	20,6 - 2100

Roping 1 : 1



GEARED SH110B

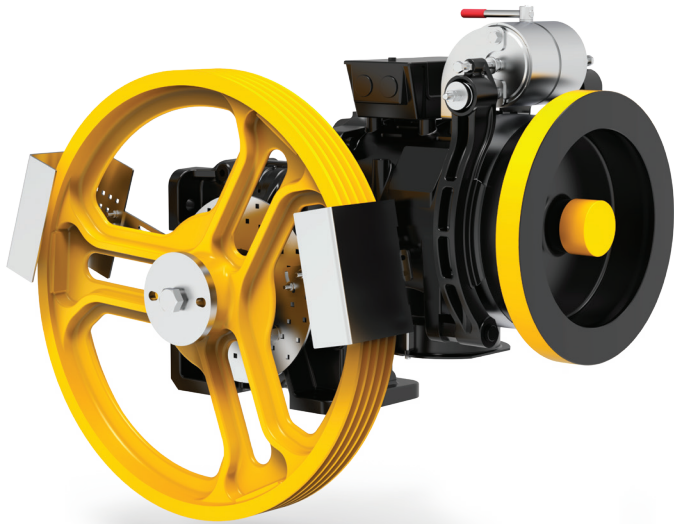

Max. Static Load SH110B	20,6 kN - 2100 kg
Power Range 50 Hz 4 poles VVVF	4 ÷ 5,5 kW
Power Range 50 Hz 4/16 poles	4 kW
Power Range 50 Hz 6 poles VVVF	2,7 ÷ 3,6 kW
Power Range 50 Hz 6/16 poles	2,7 kW
Power Range 60 Hz 4 poles VVVF	4,4 ÷ 6 kW
Power Range 60 Hz 4/16 poles	4,4 kW
Power Range 60 Hz 6 poles VVVF	4 kW
Ratio	1/55; 1/43; 2/43; 2/55
Geared Weight SH110B	200 kg
Oil capability	2,9 l
Geared machine Rh o Lh (see from motor)	Pictures Gear Lh

The geared machine efficiency values are present above each "rated load" table
The motor efficiency values are present in the table "electric motor data"

DIMENSIONS

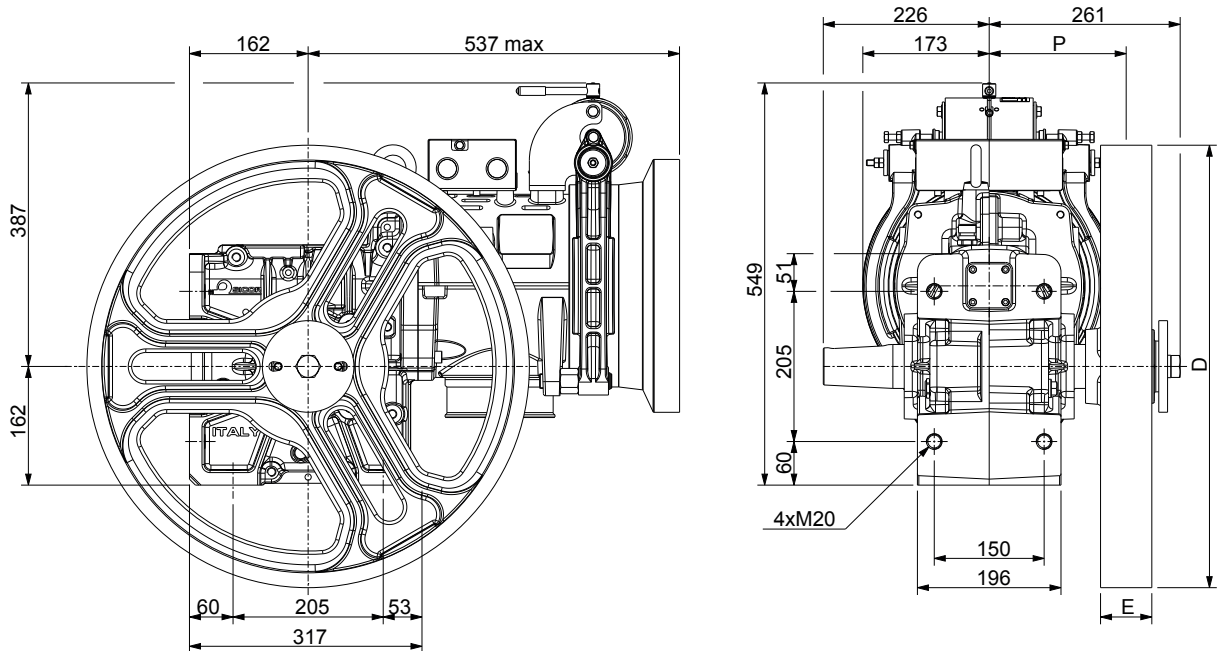

Wrapping System	Traction sheave		Dimension	Load*	Static Load Direction
	D [mm]	E [mm]	P [mm]	F [kN - kg]	
CSW	320	76	190	20,6 - 2100	
	360				
	400				
	450	70	187		
	480				
	520				
	550				
600					

*) Max. static load on the slow shaft: CSW:Conventional single wrap

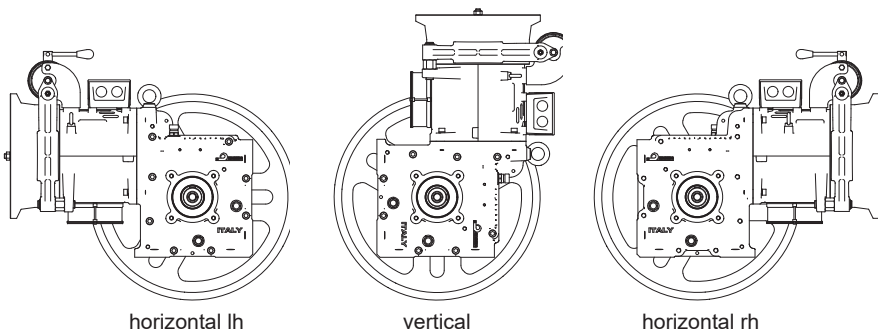

Brake Electromagnet		
[V]	[A]	[W]
24	5,25	126
48	2,30	110
60	1,77	106
80	1,50	120
110	1,02	112
200	0,63	126

DUTY TABLE

Roping 1:1

		50Hz			60Hz			50Hz			60Hz	
		VVVF 1500 rpm 4 Poles AC2 1500/375 rpm 4/16 Poles			VVVF 1800 rpm 4 Poles AC2 1800/450 rpm 4/16 Poles			VVVF 1000 rpm 6 Poles AC2 1000/375 rpm 6/16 Poles			VVVF 1200 rpm 6 Poles	
		Motor Output [kW]										
		VVVF/AC2 4		VVVF 5,5	VVVF/AC2 4,4		VVVF 6	VVVF/AC2 2,7		VVVF 3,6	VVVF 4	
R.R.	Traction Sheave Ø	Speed syn.	Max Rated Load		Speed syn.	Max Rated Load		Speed syn.	Max Rated Load		Speed syn.	Max Rated Load
[i]	[mm]	[m/s]	[kg]	[kg]	[m/s]	[kg]	[kg]	[m/s]	[kg]	[kg]	[m/s]	[kg]
1/55	320	0,46	650	--	0,55	650	--	0,30	650	--	0,37	650
1/55	360	0,51	615	--	0,62	615	--	0,34	615	--	0,41	615
1/55	400	0,57	550	--	0,69	550	--	0,38	550	--	0,46	550
1/43	320	0,58	650	--	0,70	650	--	0,39	650	--	0,47	650
1/55	450	0,64	490	--	0,77	490	--	0,43	490	--	0,51	490
1/43	360	0,66	630	--	0,79	630	--	0,44	650	--	0,53	650
1/55	480	0,69	460	--	0,82	460	--	0,46	460	--	0,55	460
1/43	400	0,73	570	--	0,88	570	--	0,49	610	--	0,58	610
1/55	520	0,74	425	--	0,89	425	--	0,50	425	--	0,59	425
1/55	550	0,79	400	--	0,94	400	--	0,52	400	--	0,63	400
1/43	450	0,82	505	--	0,99	505	--	0,55	540	--	0,66	540
1/55	600	0,86	365	--	1,03	365	--	0,57	365	--	0,69	365
1/43	480	0,88	475	--	1,05	475	--	0,58	505	--	0,70	505
2/55	320	0,91	540	650	1,10	490	650	0,61	550	650	0,73	650
1/43	520	0,95	435	--	1,14	435	--	0,63	470	--	0,76	470
1/43	550	1,00	415	--	1,21	415	--	0,67	440	--	0,80	440
2/55	360	1,03	480	605	1,23	435	605	0,69	490	605	0,82	605
1/43	600	1,10	380	--	1,32	380	--	0,73	405	--	0,88	405
2/55	400	1,14	430	545	1,37	390	545	0,76	440	545	0,91	545
2/43	320	1,17	430	610	1,40	390	550	0,78	435	600	0,94	550
2/55	450	1,29	385	485	1,54	345	485	0,86	390	485	1,03	485
2/43	360	1,32	380	540	1,58	345	485	0,88	390	530	1,05	490
2/55	480	1,37	360	455	1,65	325	455	0,91	365	455	1,10	455
2/43	400	1,46	345	485	1,75	310	440	0,97	350	480	1,17	440
2/55	520	1,49	330	420	1,78	300	420	0,99	335	420	1,19	420
2/55	550	1,57	315	395	1,88	285	395	1,05	320	395	1,26	395
2/43	450	1,64	305	430	1,97	275	390	1,10	310	425	1,32	390
2/55	600	1,71	285	360	2,06	260	360	1,14	290	360	1,37	360
2/43	480	1,75	285	405	2,10	260	365	1,17	290	400	1,40	365
2/43	520	1,90	265	375	2,28	240	335	1,27	270	365	1,52	335
2/43	550	2,01	250	355	2,41	225	320	1,34	255	345	1,61	320
2/43	600	2,19	230	325	2,63	205	290	1,46	230	320	1,75	290

		50Hz			60Hz			50Hz			60Hz	
		Potenza Motore [kW]										
		VVVF/AC2 4		VVVF 5,5	VVVF/AC2 4,4		VVVF 6	VVVF/AC2 2,7		VVVF 3,6	VVVF 4	
R.R.	Max Output Torque	Geared Efficiency		Max Output Torque	Geared Efficiency		Max Output Torque	Geared Efficiency		Max Output Torque	Geared Efficiency	
[i]	[Nm]			[Nm]			[Nm]			[Nm]		
1/55	680	0,72	0,74	680	0,71	0,73	680	0,72	0,74	680	0,73	0,73
1/43	700	0,74	0,76	700	0,73	0,76	750	0,74	0,76	750	0,76	0,76
2/55	670	0,80	0,82	670	0,79	0,81	670	0,80	0,82	670	0,82	0,82
2/43	700	0,81	0,84	700	0,80	0,83	740	0,82	0,84	740	0,83	0,83

Rated load values listed in the table include the weight of the ropes.

To know the theoretical load, subtract the weight of the ropes.

Position Of The Geared = Top Counterweight = 50% Plant efficiency = 0,80

		50Hz					
		VVVF 1500 rpm 4 Poles AC2 1500/375 rpm 4/16 Poles			VVVF 1000 rpm 6 Poles AC2 1000/375 rpm 6/16 Poles		
		Asynchronous Rated Power [kW]					
		VVVF 4	VVVF 5,5	AC2 4	VVVF 2,7	VVVF 3,6	AC2 2,7
		Motor Parameters					
Rated Voltage (star connection) ⁽¹⁾⁽³⁾	[V]	400	400	400	400	400	400
Frequency	[Hz]	50	50	50	50	50	50
Synchronous Speed	[rpm]	1500	1500	1500/375	1000	1000	1000/375
Asynchronous Speed	[rpm]	1423	1424	1359/276	955	962	893/268
Rated Current ⁽²⁾	[A]	9,4	12,4	11,3/11,1	8,4	10,9	10,9/11,5
Rated Torque	[Nm]	26,8	36,9	28,1	27	35,7	28,9
Cos φ Power Factor	[]	0,76	0,78	0,64	0,61	0,62	0,52
Starting Current	[A]	41	51	39	30	43	29
Starting Torque	[Nm]	54	78	79	46	80	69
Duty Cycle	[%]	60	60	30+10	60	60	30+10
Starts per Hour	[s/h]	240	240	180	240	240	180
Insulation Class	[]	F	F	F	F	F	F
Degree of Protection IP	[]	IP21	IP21	IP21	IP21	IP21	IP21
Dimension (B)	[mm]	507	507	507	--	--	--

(1) The motors are standard supplied with star connection (Y), the customer can arrange a delta connection (Δ).

(2) The indicated current values are related to 400V voltage. For current values with delta connection, multiply the values by 1,732.

(3) The standard supply voltage is suitable for 380-400V/220-230V power supplies.

The geared machine includes a fan, 1~220...240V, 50/60Hz, 0,7A.

Available on request 115V supply voltage.

The inertia value includes the high speed shaft, while the flywheel is excluded.

		60Hz			
		VVVF 1800 rpm 4 Poles AC2 1800/450 rpm 4/16 Poles			VVVF 1200 rpm 6 Poles
		Asynchronous Rated Power [kW]			
		VVVF 4,4	VVVF 6	AC2 4,4	VVVF 4
		Motor Parameters			
Rated Voltage (star connection) ⁽¹⁾⁽³⁾	[V]	400	400	400	400
Frequency	[Hz]	60	60	60	60
Synchronous Speed	[rpm]	1800	1800	1800/450	1200
Asynchronous Speed	[rpm]	1714	1708	1606/330	1138
Rated Current ⁽²⁾	[A]	10,2	15,2	11,8/10	12,4
Rated Torque	[Nm]	24,5	33,5	26,2	33,6
Cos φ Power Factor	[]	0,75	0,7	0,63	0,6
Starting Current	[A]	48	70	39	49
Starting Torque	[Nm]	44	70	64	62
Duty Cycle	[%]	60	60	30+10	60
Starts per Hour	[s/h]	240	240	180	240
Insulation Class	[]	F	F	F	F
Degree of Protection IP	[]	IP21	IP21	IP21	IP21

(1) The motors are standard supplied with star connection (Y), the customer can arrange a delta connection (Δ).

(2) The indicated current values are related to 400V voltage. For current values with delta connection, multiply the values by 1,732.

(3) The standard supply voltage is suitable for 380-400V/220-230V power supplies.

The geared machine includes a fan, 1~220...240V, 50/60Hz, 0,7A.

Available on request 115V supply voltage.

The inertia value includes the high speed shaft, while the flywheel is excluded.

TRACTION SHEAVES AND GROOVES NUMBER x ROPES DIAMETER

Wrapping System	Traction sheave		Max n° Grooves x D	Grooves Pitch
	D [mm]	E [mm]	n° x mm	l [mm]
CSW	320	76	5xD8	14
	360	70	5xD8	14
	360	70	4xD9	17
	400	70	5xD8	14
	400	70	4xD9	17
	400	70	4xD10	17
	450	70	5xD8	14
	450	70	4xD9	17
	450	70	4xD10	17
	450	70	4xD11	17
	480	70	5xD8	14
	480	70	4xD9	17
	480	70	4xD10	17
	480	70	4xD11	17
	480	70	3xD12	19
	520	70	5xD8	14
	520	70	4xD9	17
	520	70	4xD10	17
	520	70	4xD11	17
	520	70	3xD12	19
	520	70	3xD13	19
	550	70	5xD8	14
	550	70	4xD9	17
	550	70	4xD10	17
	550	70	4xD11	17
	550	70	3xD12	19
	550	70	3xD13	19
	600	70	5xD8	14
	600	70	4xD9	17
	600	70	4xD10	17
	600	70	4xD11	17
	600	70	3xD12	19
600	70	3xD13	19	

VCI

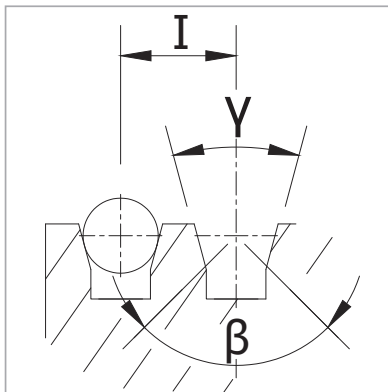

V grooves with undercut

UCI

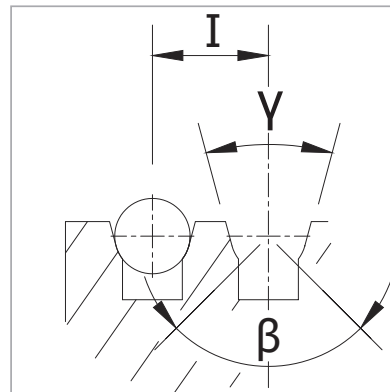

U grooves with undercut

γ = groove angle
 β = undercut angle
 I = grooves pitch

BEDPLATE | TOP MACHINE WITHOUT DIVERTING PULLEY FOR CSW WRAPPING

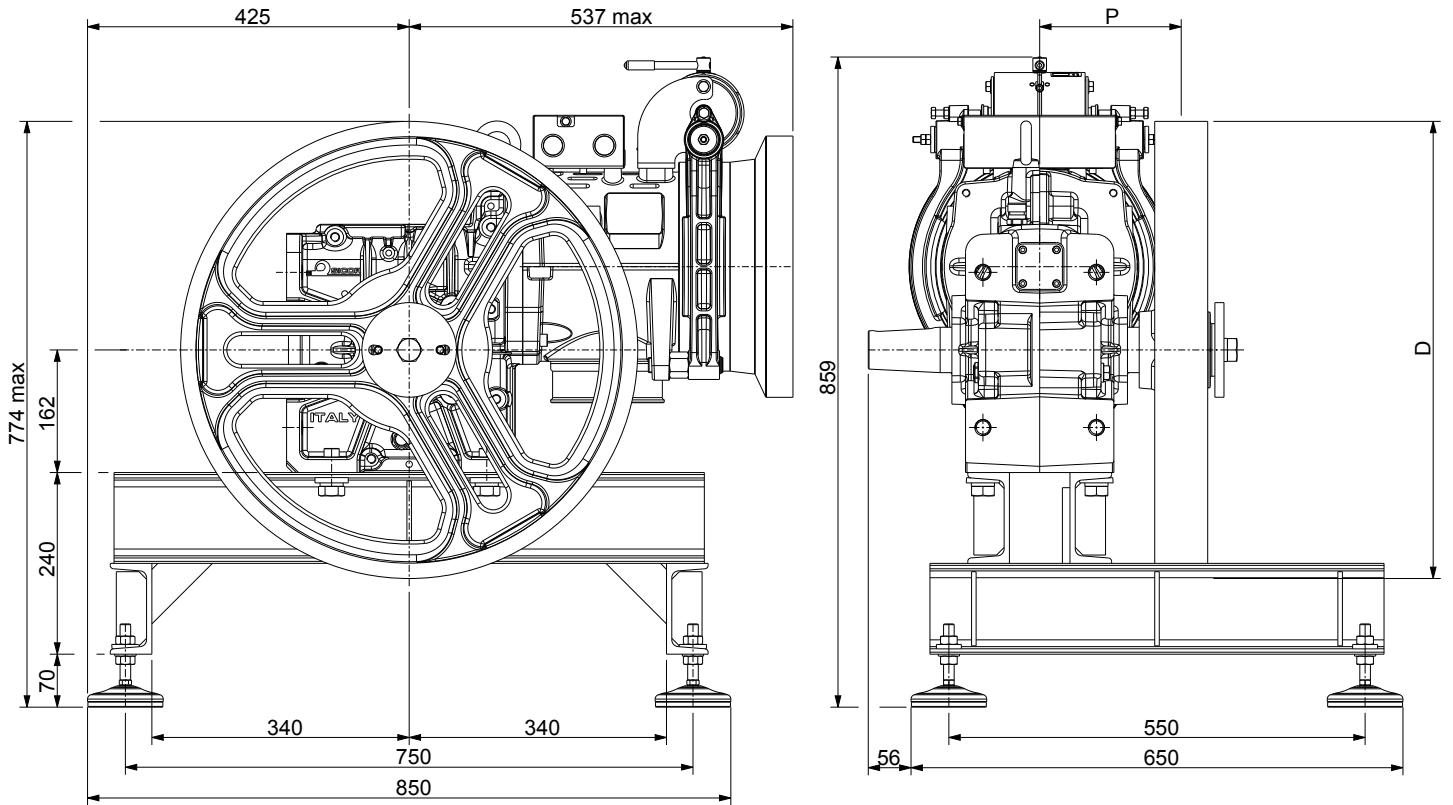

XTE0456 (included vibration dampers)
 Weight of machine bedplate: 49 kg
 (bedplate + vibration dampers)

VIBRATIONS DAMPER SET UP FOR MACHINE BEDPLATE XTE0456

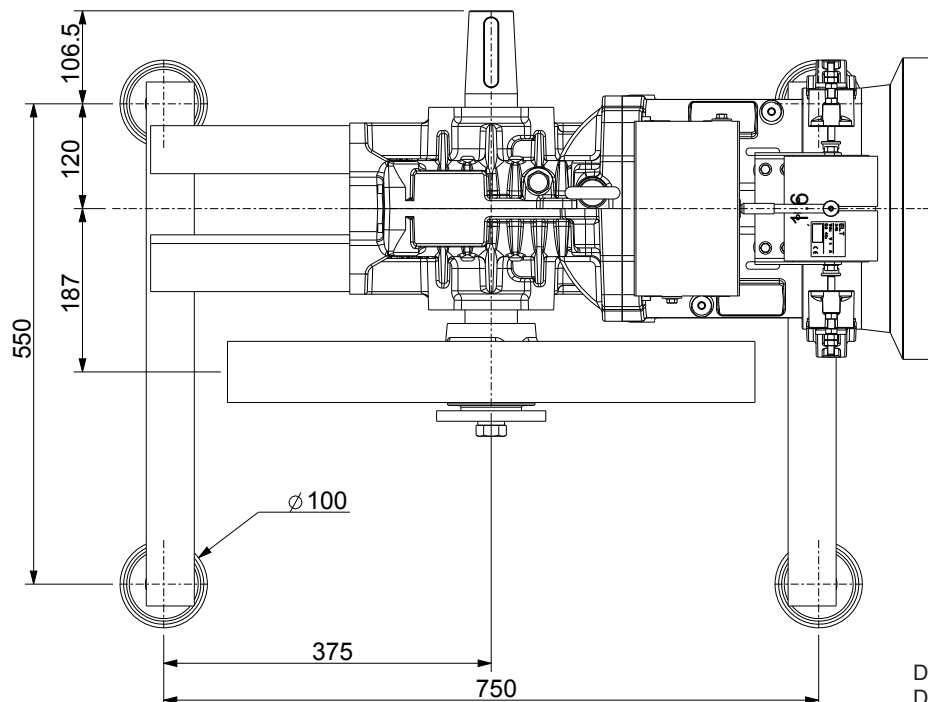

Damper code **TAI0110**
 Dimension [mm] **D.100 x 28**

BEDPLATE | TOP MACHINE WITH DIVERTING PULLEY FOR CSW WRAPPING

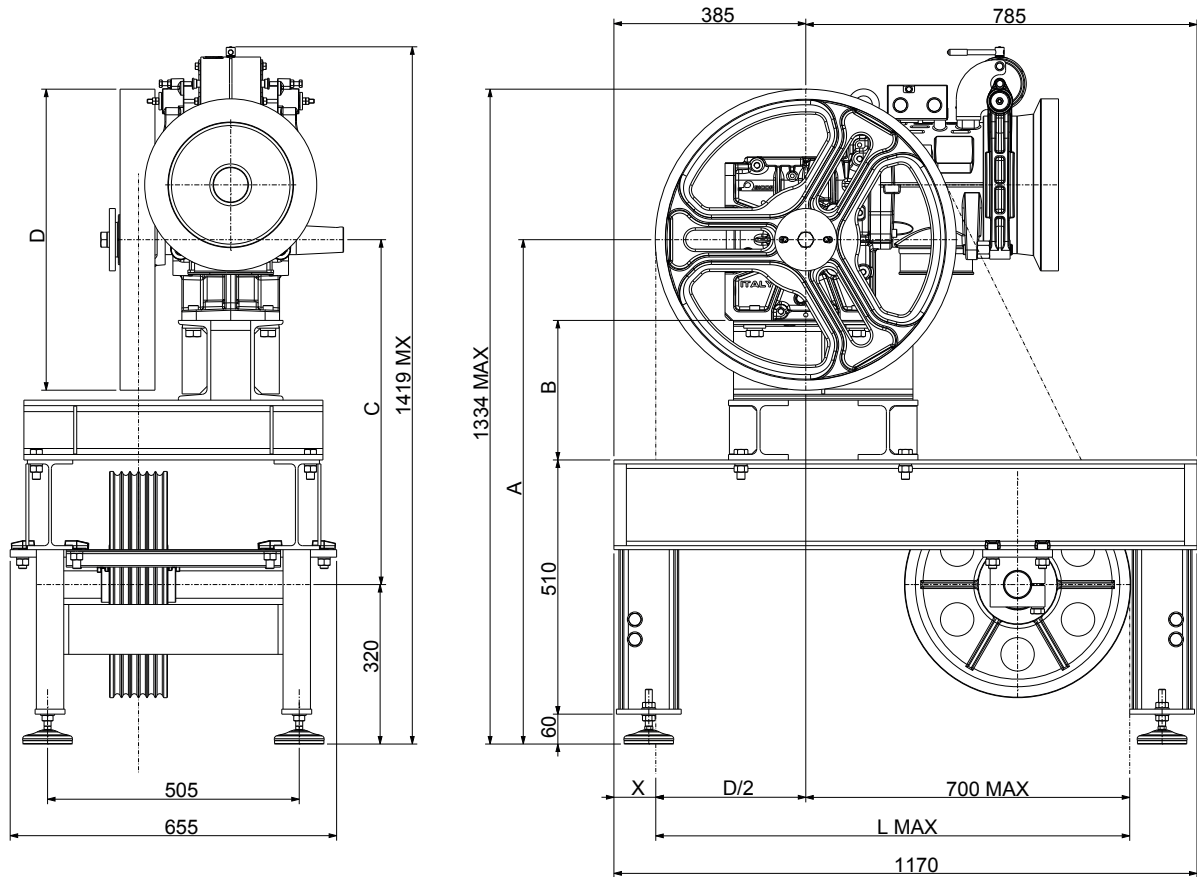

Diverting Pulley	A	B	C
Dt [mm]	[mm]	[mm]	[mm]
400	1012	280	692
450	1012	280	692
520	1032	300	712

Traction Sheave	X	L max
D [mm]	[mm]	[mm]
360	200	880
400	180	900
450	155	925
480	140	940
520	120	960
550	105	975
600	80	1000

XTE0516 (Dt 520)–**XTE0517** (Dt 400-450) (included vibration dampers)
 Weight of machine bedplate: (XTE0516) 163 kg,
 (XTE0517) 153Kg
 (bedplate + diverting pulley + vibration dampers)

VIBRATIONS DAMPER SET UP FOR MACHINE BEDPLATE XTE0516 AND XTE0517

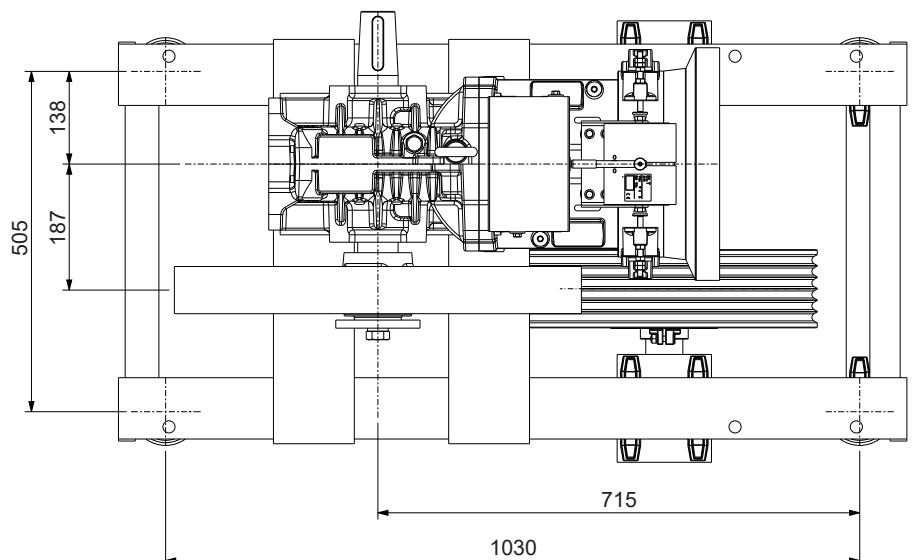

Damper code **TAI0110**
 Dimension [mm] **D.100 x 28**

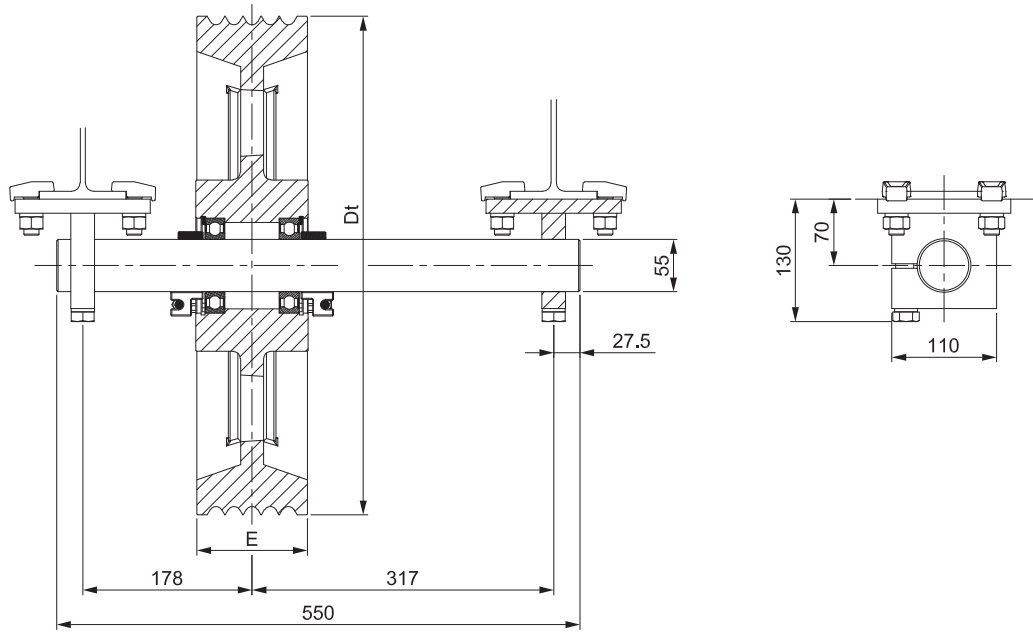

Diverting Pulley		Max n°Grooves x D	Grooves Pitch
Dt [mm]	E [mm]	n° x mm	l [mm]
400	116	7xD8	14
450	116	6xD11	17
520	116	5xD13	19



Sicor S.R.L.

Viale Caproni, 32 Rovereto (TN) - Italy • Tel: +39 0464 484 111 • info@sicoritaly.com

www.sicoritaly.com