

MR26

GEARED MACHINES

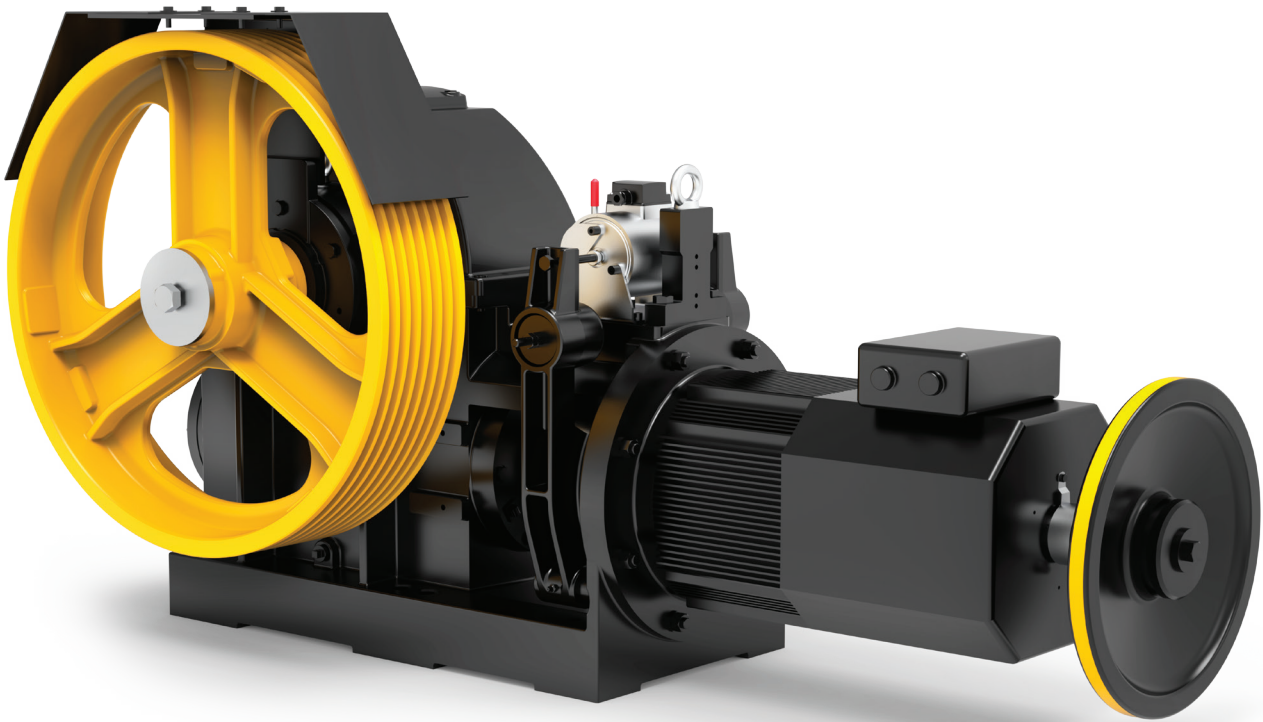

Model	For rated loads up to	Speed range synchronous	Traction sheaves diameter	Max Static Load	Carico statico Max
	[kg]	50Hz [m/s]	60Hz [m/s]	[mm]	[kN-kg]
MR26	3000	0,41 ... 3,43	0,49 ... 4,11	560,600,650, 690,750,800	64,7 - 6600 80,2 - 8175 (TS)

Roping 1 : 1



GEARED MR26

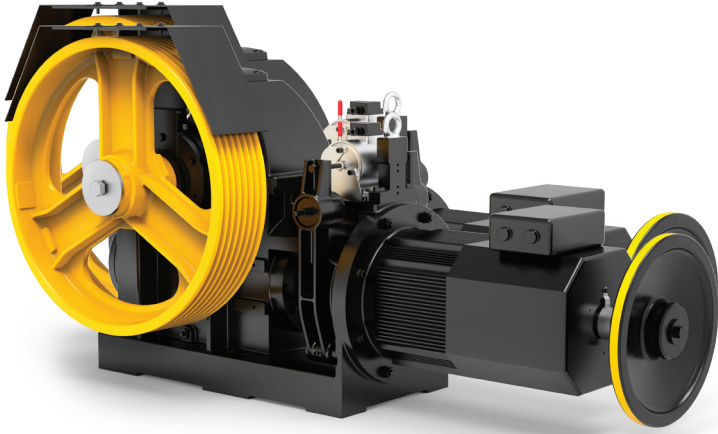

Max. Static Load MR26	64,7 kN - 6600 kg
Max. Static Load MR26TS	80,2 kN - 8175 kg
Power Range 50 Hz 4 poles VVVF	13,5 ÷ 43 kW
Power Range 50 Hz 4/16 poles	13,5 ÷ 30 kW
Power Range 33 Hz 4 poles	11 ÷ 29 kW
Power Range 50 Hz 6 poles VVVF	11 ÷ 29 kW (on request)
Power Range 60 Hz 4 poles VVVF	15 ÷ 47 kW
Power Range 60 Hz 4/16 poles	15 ÷ 33 kW
Ratio	1/72; 1/57; 1/44; 2/63; 2/45; 3/55
Geared Weight	1200 ÷ 1600 kg
Oil capability	10,8 l
Geared machine Rh o Lh (see from motor)	Pictures Gear Lh

*The geared machine efficiency values are present above each "rated load" table
The motor efficiency values are present in the table "electric motor data"*

DIMENSIONS MR26

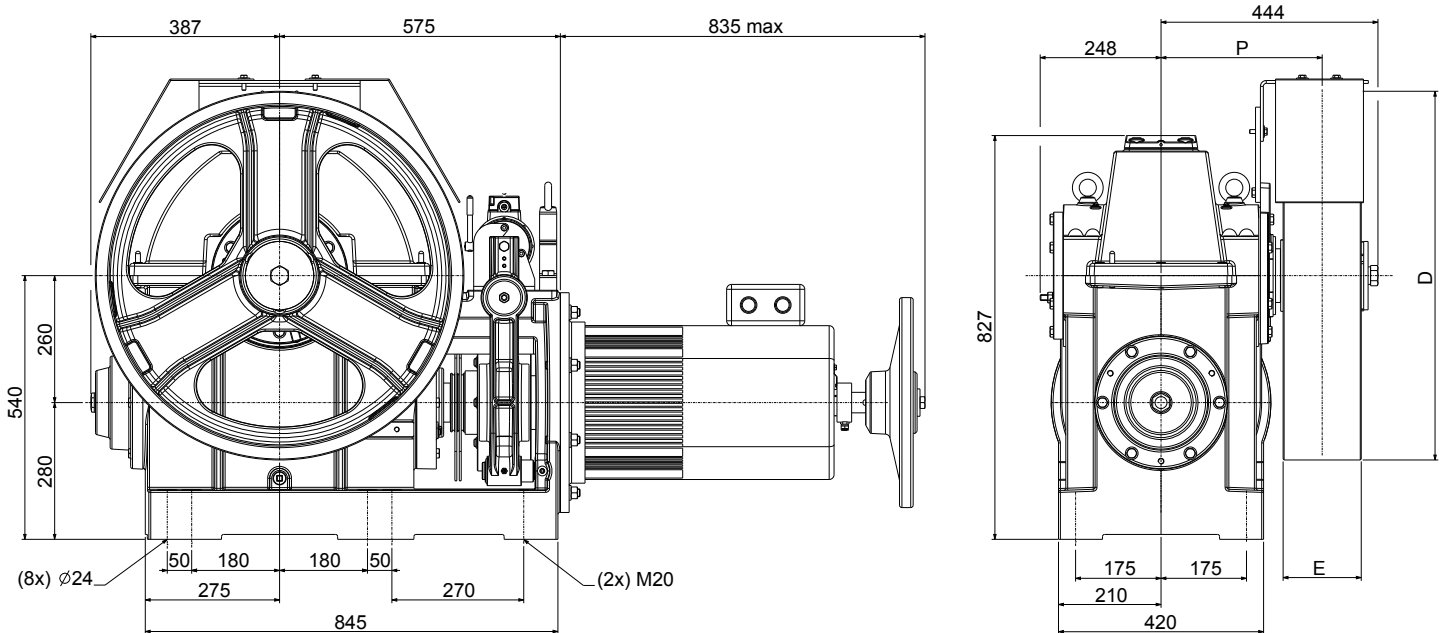

Wrapping System	Traction sheave		Dimension	Load*)
	D [mm]	E [mm]		
ESW	560	236	347	59 - 6000
	600	160		
CSW	650	160	330	64,7 - 6600
	690	160		
	750	160		
	800	160		

*) Max. static load on the slow shaft:

CSW: Conventional single wrap

ESW: Extended single wrap (patented)

**) For the B value refer to "Electric motor data" table

Brake Electromagnet		
[V]	[A]	[W]
48	5,16	243
60	4,2	252
80	3,2	252
110	2,3	253
205	1,3	262

DIMENSIONS MR26TS

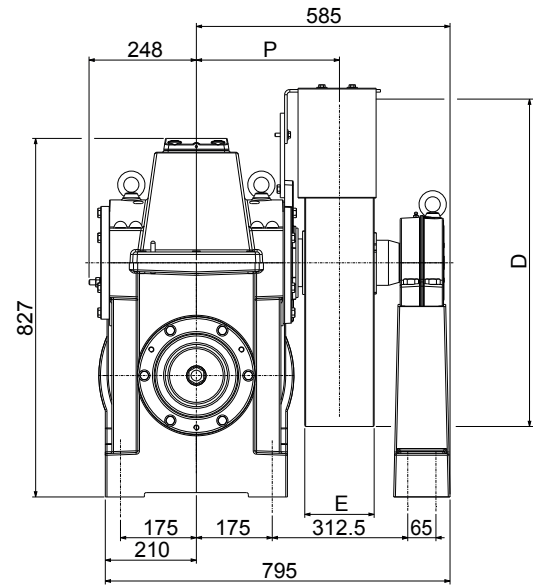
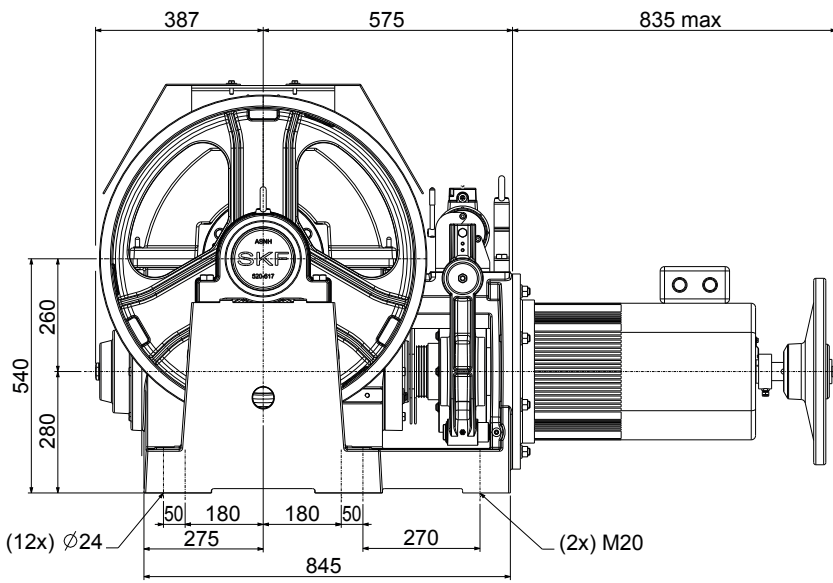

Wrapping System	Traction sheave		Dimension	Load*)
	D [mm]	E [mm]	P [mm]	F [kN - kg]
ESW	560	236	347	70 - 7150
	600	160		
CSW	650	160	330	80,21) - 81751) 702) - 71502)
	690	160		
	750	160		
	800	160		

*) Max. static load on the slow shaft:
 CSW: Conventional single wrap F= 80,2 kN1)
 horizontal component not to exceed F= 70 kN2)
 ESW: Extended single wrap (patented)

**) For the B value refer to "Electric motor data" table

Brake Electromagnet		
[V]	[A]	[W]
48	5,16	243
60	4,2	252
80	3,2	252
110	2,3	253
205	1,3	262

Wrapping system		R.R.	Traction Sheave Ø	Speed syn.	Max Rated Load									
CSW	ESW	[i]	[mm]	[m/s]	[kg]	[kg]	[kg]	[kg]	[kg]	[kg]	[kg]	[kg]	[kg]	[kg]
--	X	1/72	560	0,61	2175	2650	--	--	--	--	--	--	--	--
X	--	1/72	600	0,65	2030	2615	2650	--	--	--	--	--	--	--
X	--	1/72	650	0,71	1875	2410	2650	--	--	--	--	--	--	--
X	--	1/72	690	0,75	1765	2270	2560	--	--	--	--	--	--	--
--	X	1/57	560	0,77	1785	2305	2650	--	--	--	--	--	--	--
X	--	1/72	750	0,82	1625	2090	2355	--	--	--	--	--	--	--
X	--	1/57	600	0,83	1665	2155	2650	--	--	--	--	--	--	--
X	--	1/72	800	0,87	1520	1960	2205	--	--	--	--	--	--	--
X	--	1/57	650	0,90	1540	1985	2510	2650	--	--	--	--	--	--
X	--	1/57	690	0,95	1450	1870	2365	2650	--	--	--	--	--	--
--	X	1/44	560	1,00	1410	1820	2305	2650	--	--	--	--	--	--
X	--	1/57	750	1,03	1335	1720	2175	2580	--	--	--	--	--	--
X	--	1/44	600	1,07	1315	1700	2150	2650	--	--	--	--	--	--
X	--	1/57	800	1,10	1250	1615	2040	2420	--	--	--	--	--	--
X	--	1/44	650	1,16	1210	1570	1985	2580	2650	--	--	--	--	--
X	--	1/44	690	1,23	1140	1480	1870	2430	2650	--	--	--	--	--
X	--	1/44	750	1,34	1050	1360	1720	2235	2650	--	--	--	--	--
--	X	2/63	560	1,40	1090	1400	1760	2270	2650	--	--	--	--	--
X	--	1/44	800	1,43	985	1275	1615	2095	2485	--	--	--	--	--
X	--	2/63	600	1,50	1015	1305	1640	2120	2600	2650	--	--	--	--
X	--	2/63	650	1,62	940	1205	1515	1955	2400	2615	--	--	--	--
X	--	2/63	690	1,72	885	1135	1425	1845	2260	2465	--	--	--	--
X	--	2/63	750	1,87	815	1045	1310	1695	2080	2270	--	--	--	--
--	X	2/45	560	1,95	770	995	1255	1630	2000	2225	2520	2650	--	--
X	--	2/63	800	1,99	760	980	1230	1590	1950	2125	--	--	--	--
X	--	2/45	600	2,09	720	925	1170	1520	1865	2075	2355	2565	2650	--
X	--	2/45	650	2,27	665	855	1080	1400	1725	1915	2175	2365	2560	--
--	X	3/55	560	2,40	635	815	1030	1340	1645	1830	2075	2260	2440	--
X	--	2/45	690	2,41	625	805	1020	1320	1625	1805	2045	2230	2410	--
X	--	3/55	600	2,57	590	765	965	1250	1535	1705	1935	2105	2280	--
X	--	2/45	750	2,62	575	740	935	1215	1495	1660	1885	2050	2215	--
X	--	3/55	650	2,78	545	705	890	1155	1415	1575	1785	1945	2105	--
X	--	2/45	800	2,79	540	695	880	1140	1400	1555	1765	1920	2080	--
X	--	3/55	690	2,96	515	665	835	1085	1335	1485	1685	1830	1980	--
X	--	3/55	750	3,21	470	610	770	1000	1230	1365	1550	1685	1825	--
X	--	3/55	800	3,43	445	570	720	935	1150	1280	1450	1580	1710	--

R.R.		Max Output Torque	Geared Efficiency							
[i]	[Nm]									
1/72	5420	0,63	0,67	0,69	0,72	0,74	0,74	0,75	0,76	0,76
1/57	5940	0,66	0,70	0,72	0,75	0,77	0,78	0,79	0,79	0,80
1/44	6100	0,67	0,71	0,74	0,77	0,79	0,80	0,81	0,82	0,82
2/63	5220	0,73	0,76	0,79	0,82	0,84	0,84	0,85	0,86	0,86
2/45	5550	0,72	0,76	0,79	0,82	0,84	0,85	0,86	0,86	0,87
3/55	5580	0,73	0,77	0,80	0,83	0,85	0,86	0,87	0,87	0,88

Rated load values listed in the table include the weight of the ropes.
 To know the theoretical load, subtract the weight of the ropes.
 Position Of The Geared = Top Counterweight = 50% Plant efficiency = 0,80

60Hz										33Hz						
VVVF 1800 rpm 4 Poles AC2 1800/450 rpm 4/16 Poles										VVVF 1000 rpm 6 Poles						
Motor Output [kW]																
	VVVF AC2 15	VVVF AC2 18	VVVF AC2 22	VVVF AC2 27	VVVF AC2 33	VVVF 36	VVVF 40	VVVF 44	VVVF 47		VVVF 11	VVVF 13,5	VVVF 16,5	VVVF 20	VVVF 25	VVVF 29
Speed syn.	Max Rated Load									Speed syn.	Max Rated Load					
[m/s]	[kg]	[kg]	[kg]	[kg]	[kg]	[kg]	[kg]	[kg]	[kg]	[m/s]	[kg]	[kg]	[kg]	[kg]	[kg]	[kg]
0,73	2035	2455	--	--	--	--	--	--	--	0,41	2637	2650	--	--	--	--
0,79	1895	2290	--	--	--	--	--	--	--	0,44	2635	2650	--	--	--	--
0,85	1750	2115	--	--	--	--	--	--	--	0,47	2430	2650	--	--	--	--
0,90	1650	1995	--	--	--	--	--	--	--	0,50	2290	2560	--	--	--	--
0,93	1655	2090	2650	--	--	--	--	--	--	0,51	2325	2650	--	--	--	--
0,98	1515	1835	--	--	--	--	--	--	--	0,55	2105	2355	--	--	--	--
0,99	1545	1950	2490	2650	--	--	--	--	--	0,55	2170	2650	--	--	--	--
1,05	1420	1720	--	--	--	--	--	--	--	0,58	1975	2205	--	--	--	--
1,07	1425	1800	2295	2500	--	--	--	--	--	0,60	2005	2565	2650	--	--	--
1,14	1340	1695	2165	2355	--	--	--	--	--	0,63	1890	2415	2650	--	--	--
1,20	1315	1665	2125	2650	--	--	--	--	--	0,67	1840	2355	2650	--	--	--
1,24	1235	1560	1990	2170	--	--	--	--	--	0,69	1735	2220	2580	--	--	--
1,29	1230	1550	1980	2520	2620	--	--	--	--	0,71	1715	2200	2650	--	--	--
1,32	1155	1460	1865	2030	--	--	--	--	--	0,73	1630	2085	2420	--	--	--
1,39	1135	1430	1830	2325	2415	--	--	--	--	0,77	1585	2030	2565	2650	--	--
1,48	1070	1350	1725	2190	2275	--	--	--	--	0,82	1490	1910	2415	2650	--	--
1,61	985	1240	1585	2015	2095	--	--	--	--	0,89	1370	1760	2225	2650	--	--
1,68	1020	1275	1620	2045	2350	--	--	--	--	0,93	1410	1795	2260	2650	--	--
1,71	920	1165	1485	1890	1965	--	--	--	--	0,95	1285	1650	2085	2485	--	--
1,80	950	1190	1510	1910	2195	--	--	--	--	1,00	1315	1675	2110	2610	2650	--
1,94	875	1100	1395	1765	2025	--	--	--	--	1,08	1215	1545	1945	2410	2615	--
2,06	825	1035	1315	1660	1905	--	--	--	--	1,15	1145	1455	1835	2270	2465	--
2,24	760	950	1205	1525	1755	--	--	--	--	1,25	1055	1340	1685	2090	2270	--
2,35	710	895	1145	1455	1830	2015	2265	2510	2650	1,30	1005	1280	1620	2010	2570	2650
2,39	710	890	1130	1430	1645	--	--	--	--	1,33	985	1255	1580	1960	2125	--
2,51	660	835	1070	1360	1705	1880	2110	2345	2520	1,40	935	1195	1510	1875	2395	2650
2,72	610	770	985	1255	1575	1735	1950	2165	2325	1,51	865	1105	1395	1730	2210	2600
2,88	590	745	950	1205	1510	1665	1870	2075	2225	1,60	825	1055	1330	1650	2110	2480
2,89	575	725	930	1180	1485	1635	1835	2040	2190	1,61	815	1040	1315	1630	2085	2445
3,08	550	695	885	1125	1410	1555	1745	1935	2080	1,71	770	985	1240	1540	1970	2315
3,14	530	670	855	1085	1365	1505	1690	1875	2015	1,75	750	955	1205	1500	1915	2250
3,34	510	640	815	1040	1300	1435	1610	1785	1920	1,86	710	910	1145	1425	1820	2135
3,35	495	625	800	1020	1280	1410	1585	1755	1890	1,86	700	895	1130	1405	1795	2110
3,55	480	605	770	975	1225	1350	1515	1680	1805	1,97	670	855	1080	1340	1715	2010
3,86	440	555	710	900	1130	1240	1395	1545	1660	2,14	615	785	995	1235	1575	1850
4,11	415	520	665	845	1055	1165	1310	1450	1560	2,28	575	740	930	1155	1480	1735

60Hz										33Hz						
Motor Output [kW]																
	VVVF AC2 15	VVVF AC2 18	VVVF AC2 22	VVVF AC2 27	VVVF AC2 33	VVVF 36	VVVF 40	VVVF 44	VVVF 47		VVVF 11	VVVF 13,5	VVVF 16,5	VVVF 20	VVVF 25	VVVF 29
Max Output Torque	Geared Efficiency									Max Output Torque	Geared Efficiency					
[Nm]										[Nm]						
4220	0,64	0,67	0,70	0,72	0,74	0,74	0,75	0,76	0,76	5420	0,67	0,70	0,72	0,74	0,75	0,76
4990	0,66	0,69	0,72	0,75	0,77	0,78	0,79	0,79	0,80	5940	0,70	0,73	0,75	0,77	0,79	0,80
4820	0,68	0,71	0,75	0,77	0,79	0,80	0,81	0,82	0,82	6100	0,72	0,75	0,77	0,79	0,81	0,82
4040	0,73	0,77	0,79	0,82	0,84	0,85	0,85	0,86	0,86	5220	0,77	0,80	0,82	0,84	0,86	0,87
4760	0,72	0,75	0,79	0,82	0,84	0,85	0,86	0,86	0,87	5550	0,77	0,80	0,82	0,84	0,86	0,87
4380	0,73	0,77	0,80	0,83	0,85	0,86	0,87	0,87	0,88	5580	0,77	0,81	0,83	0,85	0,87	0,88

50Hz															
VVVF 1500 rpm 4 Poles AC2 1500/375 rpm 4/16 Poles															
Asynchronous Rated Power [kW]															
	VVVF 13,5	VVVF 16,5	VVVF 20	VVVF 25	VVVF 30	VVVF 33	VVVF 37	VVVF 40	VVVF 43	AC2 13,5	AC2 16,5	AC2 20	AC2 25	AC2 30	
Motor Parameters															
Rated Voltage (star connection) ⁽¹⁾⁽³⁾	[V]	400	400	400	400	400	400	400	400	400	400	400	400	400	
Frequency	[Hz]	50	50	50	50	50	50	50	50	50	50	50	50	50	
Synchronous Speed	[rpm]	1500	1500	1500	1500	1500	1500	1500	1500	1500/375	1500/375	1500/375	1500/375	1500/375	
Asynchronous Speed	[rpm]	1464	1460	1462	1459	1459	1461	1456	1460	1457	1340/280	1340/270	1365/275	1384/300	1350/305
Rated Current ⁽²⁾	[A]	27	34	42	50	59	66	74	80	86	39/24	42/27	47/33	59/39	69/51
Rated Torque	[Nm]	88	108	131	164	196	216	243	262	282	96	118	140	173	212
Cos φ Power Factor	[]	0,84	0,83	0,82	0,84	0,82	0,84	0,83	0,84	0,85	--	--	--	--	--
Starting Current	[A]	128	150	150	193	235	264	296	325	325	113	144	160	207	245
Starting Torque	[Nm]	220	270	330	410	510	550	630	700	700	229	280	329	419	514
Duty Cycle	[%]	60	60	60	60	60	60	60	60	60	30+10	30+10	30+10	30+10	30+10
Starts per Hour	[s/h]	240	240	240	240	240	240	240	240	240	180	180	180	180	180
Insulation Class	[]	F	F	F	F	F	F	F	F	F	F	F	F	F	F
Degree of Protection IP	[]	IP21	IP21	IP21	IP21	IP21	IP21	IP21	IP21	IP21	IP21	IP21	IP21	IP21	IP21
Dimension (B)	[mm]	755	755	755	755	755	785	785	785	785	735	735	735	835	835

(1) The motors are standard supplied with star connection (Y), the customer can arrange a delta connection (Δ).
 (2) The indicated current values are related to 400V voltage. For current values with delta connection, multiply the values by 1,732. Motor are manufactured for 50Hz. Inverter must assure those frequencies and voltages independently from the net frequency.
 (3) The standard supply voltage is suitable for 380-400V/220-230V power supplies.
 The geared machine includes a fan, 1~220...240V, 50/60Hz, 0,7A.
 The inertia value includes the high speed shaft, while the flywheel is excluded.
 The inertia includes motor and primary shaft masses without handwheel. Handwheel inertia: 0,17kgm2.
 Phase to phase resistance = 2xR1

60Hz															
VVVF 1800 rpm 4 Poles AC2 1800/450 rpm 4/16 Poles															
Asynchronous Rated Power [kW]															
	VVVF 15	VVVF 18	VVVF 22	VVVF 27	VVVF 33	VVVF 36	VVVF 40	VVVF 44	VVVF 47	AC2 15	AC2 18	AC2 22	AC2 27	AC2 33	
Motor Parameters															
Rated Voltage (star connection) ⁽¹⁾⁽³⁾	[V]	400	400	400	400	400	400	400	400	400	400	400	400	400	
Frequency	[Hz]	60	60	60	60	60	60	60	60	60	60	60	60	60	
Synchronous Speed	[rpm]	1800	1800	1800	1800	1800	1800	1800	1800	1800/450	1800/450	1800/450	1800/450	1800/450	
Asynchronous Speed	[rpm]	1755	1755	1735	1750	1750	1747	1747	1747	1620/350	1670/320	1660/345	1675/365	1680/380	
Rated Current ⁽²⁾	[A]	38	46	57	59	66	72	80	87	93	42/25	50/33	59/41	63/40	71/52
Rated Torque	[Nm]	82	98	121	149	182	196	219	240	257	88	103	126	154	188
Cos φ Power Factor	[]	0,87	0,88	0,88	0,88	0,86	0,87	0,84	0,81	0,83	--	--	--	--	--
Starting Current	[A]	143	175	210	230	250	275	--	--	--	130	166	185	220	261
Starting Torque	[Nm]	209	250	298	410	510	--	--	--	--	211	250	298	358	430
Duty Cycle	[%]	60	60	60	60	60	60	60	60	60	30+10	30+10	30+10	30+10	30+10
Starts per Hour	[s/h]	240	240	240	240	240	240	240	240	240	180	180	180	180	180
Insulation Class	[]	F	F	F	F	F	F	F	F	F	F	F	F	F	
Degree of Protection IP	[]	IP21	IP21	IP21	IP21	IP21	IP21	IP21	IP21	IP21	IP21	IP21	IP21	IP21	
Dimension (B)	[mm]	755	755	755	755	755	785	785	785	785	735	735	735	835	835

(1) The motors are standard supplied with star connection (Y), the customer can arrange a delta connection (Δ).
 (2) The indicated current values are related to 400V voltage. For current values with delta connection, multiply the values by 1,732. Motor are manufactured for 60Hz. Inverter must assure those frequencies and voltages independently from the net frequency.
 (3) The standard supply voltage is suitable for 380-400V/220-230V power supplies.
 The geared machine is provided with fan keyed directly onto the shaft, except for some models for which the ventilation is servo-assisted by a fan 1-220...240V 50/60 hz,0,7 A
 The inertia includes motor and primary shaft masses without handwheel. Handwheel inertia: 0,17kgm2.
 Phase to phase resistance = 2xR1

33Hz							
VVVF 1000 rpm 4 Poles							
Asynchronous Rated Power [kW]							
		VVVF 11	VVVF 13,5	VVVF 16,5	VVVF 20	VVVF 25	VVVF 29
Motor Parameters							
Rated Voltage (star connection) ⁽¹⁾⁽³⁾	[V]	400	400	400	400	400	400
Frequency	[Hz]	33	33	33	33	33	33
Synchronous Speed	[rpm]	990	990	990	990	990	990
Asynchronous Speed	[rpm]	959	958	956	954	943	948
Rated Current ⁽²⁾	[A]	24	29	36	43	51	60
Rated Torque	[Nm]	110	135	165	200	253	292
Cos ϕ Power Factor	[]	0,81	0,82	0,81	0,81	0,85	0,83
Starting Current	[A]	111	135	167	205	224	242
Starting Torque	[Nm]	290	340	415	500	630	690
Duty Cycle	[%]	60	60	60	60	60	60
Starts per Hour	[s/h]	240	240	240	240	240	240
Insulation Class	[]	F	F	F	F	F	F
Degree of Protection IP	[]	IP21	IP21	IP21	IP21	IP21	IP21
Dimension (B)	[mm]	755	755	755	785	785	785

(1) The motors are standard supplied with star connection (Y), the customer can arrange a delta connection (Δ).

(2) The indicated current values are related to 400V voltage. For current values with delta connection, multiply the values by 1,732. Motor are manufactured for 50Hz. Inverter must assure those frequencies and voltages independently from the net frequency.

(3) The standard supply voltage is suitable for 380-400V/220-230V power supplies.

The geared machine includes a fan, 1~220...240V, 50/60Hz, 0,7A.

The inertia value includes the high speed shaft, while the flywheel is excluded.

The inertia includes motor and primary shaft masses without handwheel. Handwheel inertia: 0,17kgm².

Phase to phase resistance = 2xR1

TRACTION SHEAVES AND GROOVES NUMBER x ROPES DIAMETER

Wrapping System	Traction sheave		Max n° Grooves x D	Grooves Pitch	
	D [mm]	E [mm]	n° x mm	l [mm]	
ESW	560	236	8xD13	30	
	600	160	9xD10	16	
	600	160	8xD11	18	
	600	160	8xD12	18	
	600	160	8xD13	19	
	600	160	6xD14	22	
	600	160	6xD15	22	
	650	160	9xD10	16	
	650	160	8xD11	18	
	650	160	8xD12	18	
	650	160	8xD13	19	
	650	160	6xD14	22	
	650	160	6xD15	22	
	650	160	6xD16	22	
	690	160	9xD10	16	
	690	160	8xD11	18	
	690	160	8xD12	18	
	CSW	690	160	8xD13	19
		690	160	6xD14	22
		690	160	6xD15	22
690		160	6xD16	22	
750		160	9xD10	16	
750		160	8xD11	18	
750		160	8xD12	18	
750		160	8xD13	19	
750		160	6xD14	22	
750		160	6xD15	22	
750		160	6xD16	22	
800		160	9xD10	16	
800		160	8xD11	18	
800		160	8xD12	18	
800		160	8xD13	19	
800		160	6xD14	22	
800		160	6xD15	22	
800		160	6xD16	22	

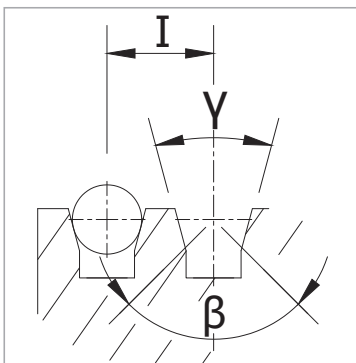
VCI

V grooves with undercut

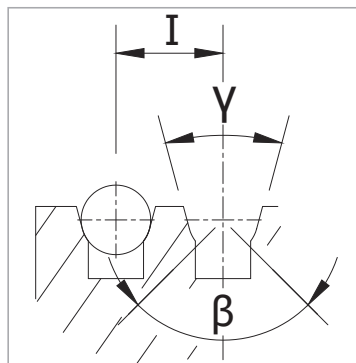
UCI

U grooves with undercut

γ = groove angle
 β = undercut angle
 I = grooves pitch

BEDPLATE | TOP MACHINE WITHOUT DIVERTING PULLEY FOR CSW WINDING (SHORT)

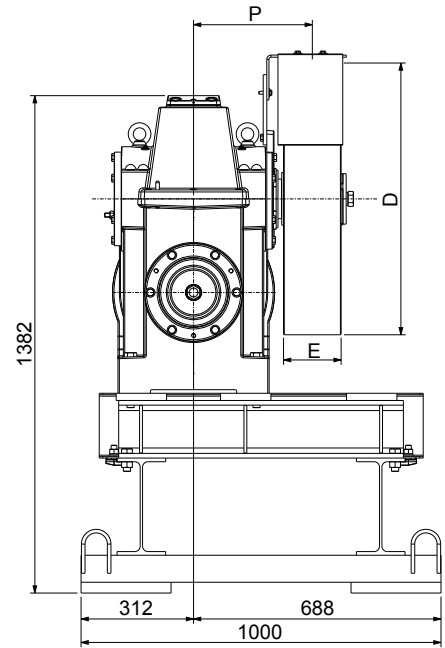
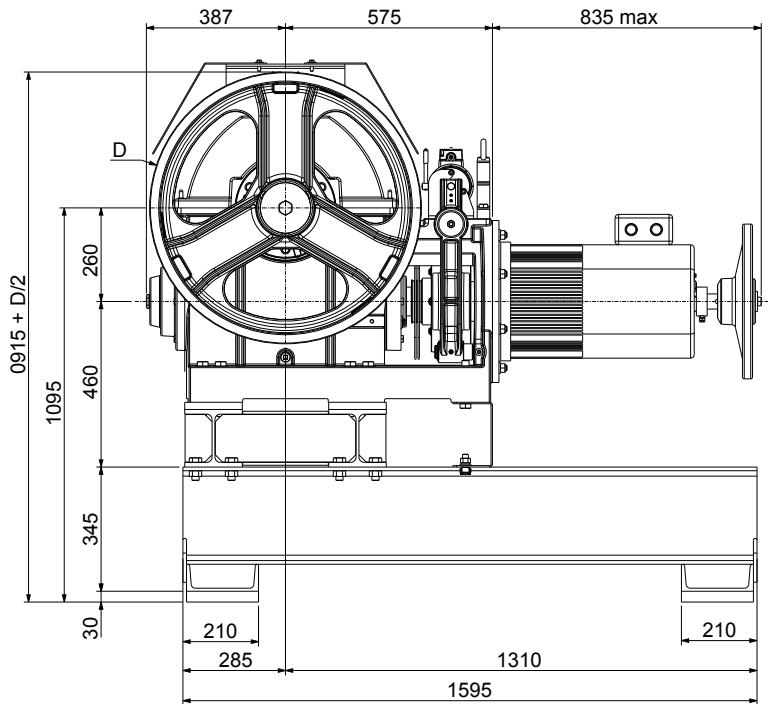

**) For the B value refer to "Electric motor data" table
 MR26 XTE2959 Weight of machine bedplate: 313 kg.
 MR26TS XTE0037 for top machine (included vibration dampers); XTE0069 for bottom/on side machine (included vibration dampers)
 Weight of machine bedplate: 165 kg (Bedplate + vibration dampers)
 Note: Machine room floor thickness min. 250 mm.

BEDPLATE | TOP MACHINE WITH DIVERTING PULLEY FOR CSW WINDING (SHORT)

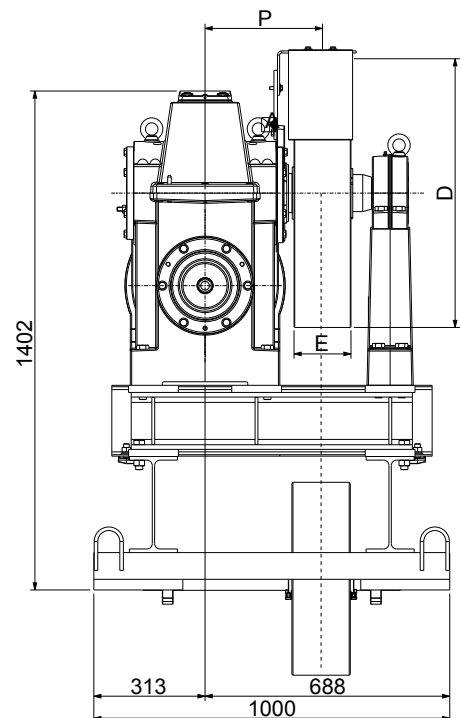
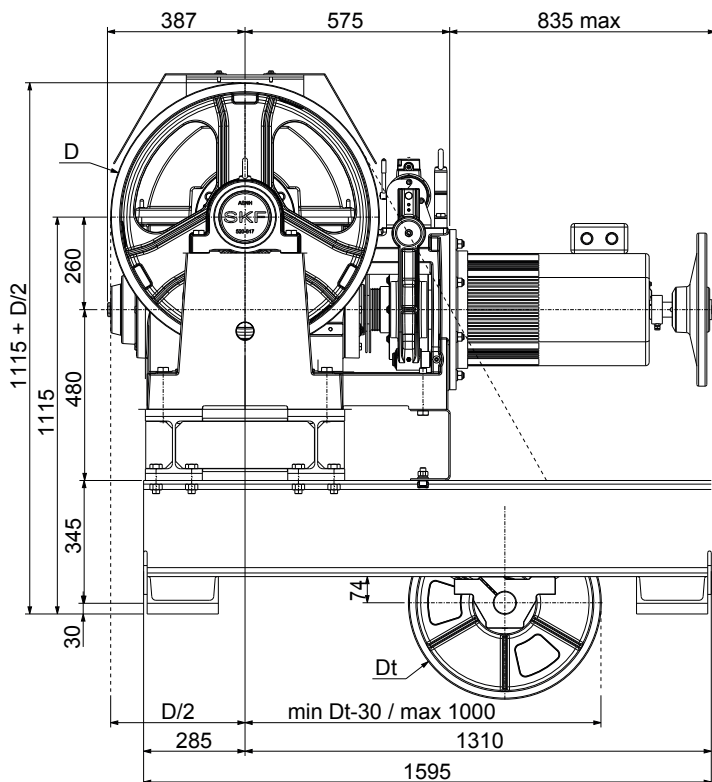

**) For the B value refer to "Electric motor data" table
 MR26 XTE2961 Weight of machine bedplate: 465 kg.
 MR26TS XTE0041 (included vibration dampers) Weight of machine bedplate: 534 kg (bedplate + diverting pulley + vibration dampers)
 Note: Machine room floor thickness min. 250 mm. (without diverting pulley)
 Dt = 534 mm
 Dimension Hmin = (Dt/2) + 75

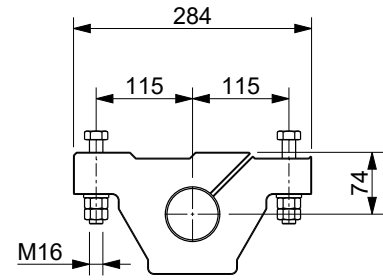
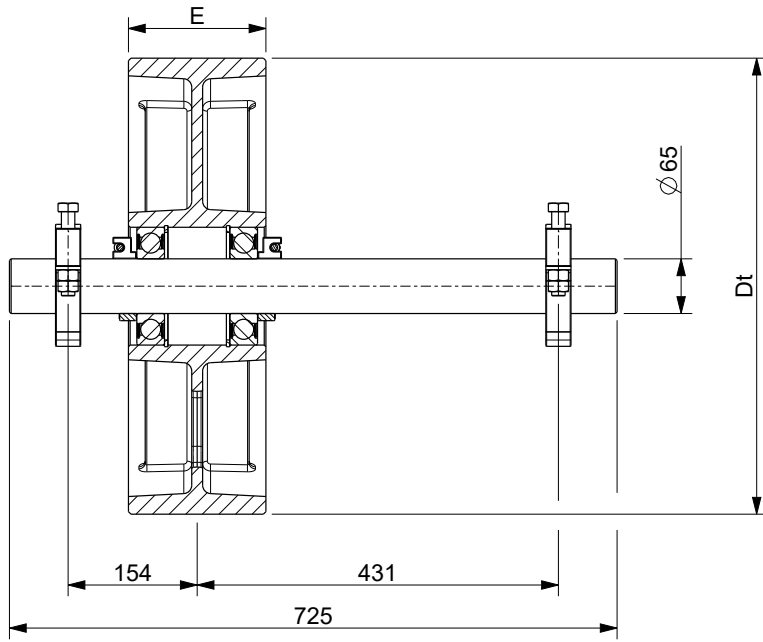

Diverting Pulley		Max n°Grooves x D	Grooves Pitch l [mm]	Distance X [mm]	Length L [mm]	Force F Max [kN]
D [mm]	E [mm]					
534	124	7xD10	16	72+90	725	23
		6xD12	18	72+90	725	23
		6xD13	19	72+90	725	23
	164	10xD10	16	72+90	725	24,2
		8xD12	18	72+90	725	24,2
		8xD13	19	72+90	725	24,2
656	186	11xD10	16	122	725	24,9
		10xD12	18	122	725	24,9
		9xD13	19	122	725	24,9
		8xD16	22	122	725	24,9



Sicor S.R.L.

Viale Caproni, 32 Rovereto (TN) - Italy • Tel: +39 0464 484 111 • info@sicoritaly.com

www.sicoritaly.com