

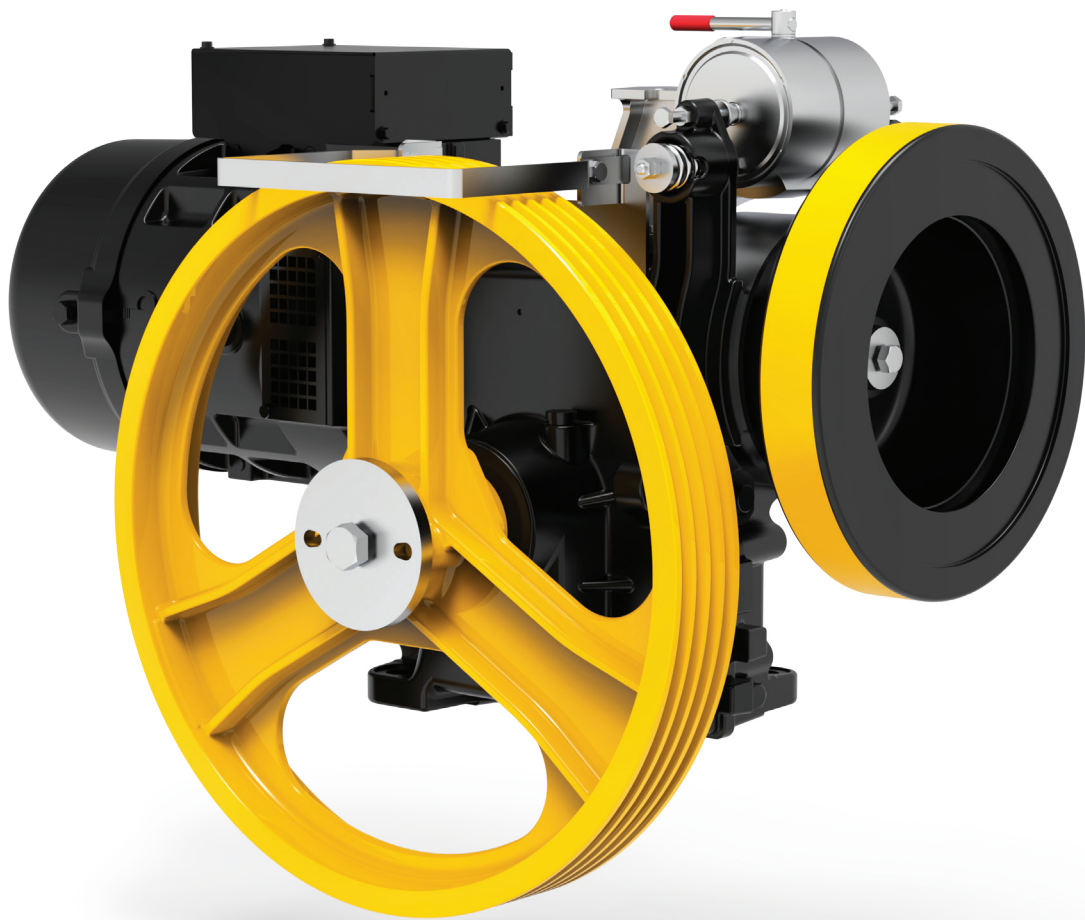

MR12C

GEARED MACHINES



Model	For rated loads up to	Speed range synchronous	Traction sheaves diameter	Max Static Load	Carico statico Max
	[kg]	50Hz [m/s]	60Hz [m/s]	[mm]	[kN-kg]
MR12C 	550	0,34 ... 2,19	0,62 ... 2,63	340,420,440, 480,550,600	25,5 - 2600

Roping 1 : 1



GEARED MR12C

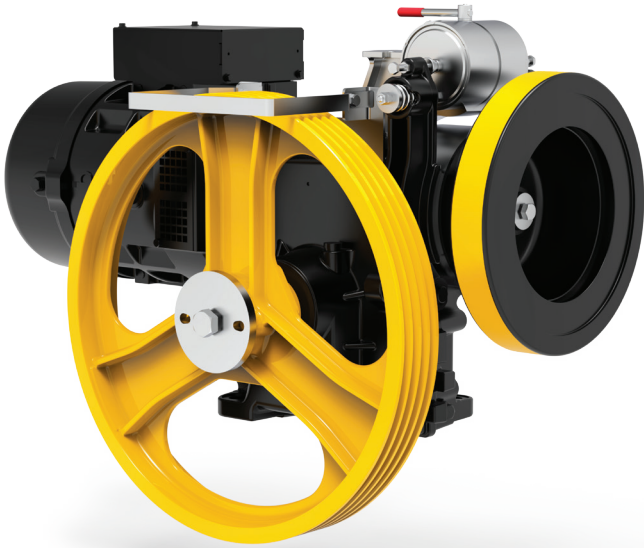

Max. Static Load	25,5 kN - 2600 kg
Power Range 50 Hz 4 poles VVVF	4 ÷ 6,7 kW
Power Range 50 Hz 4/16 poles	4 ÷ 5,5 kW
Power Range 50 Hz 6 poles VVVF	2,7 ÷ 3,6 kW
Power Range 50 Hz 6/16 poles	2,7 ÷ 3,6 kW
Power Range 60 Hz 4 poles VVVF	4,4 ÷ 6 kW
Power Range 60 Hz 4/16 poles	4,4 ÷ 6 kW
Power Range 60 Hz 6 poles VVVF	4 kW
Power Range 60 Hz 6/16 poles	4 kW
Ratio	1/55; 1/43; 2/43; 2/55
Geared Weight	240 kg
Oil capability	3,8 l
Geared machine Rh o Lh (see from motor)	Pictures Gear Rh

The geared machine efficiency values are present above each "rated load" table
The motor efficiency values are present in the table "electric motor data"

DIMENSIONS

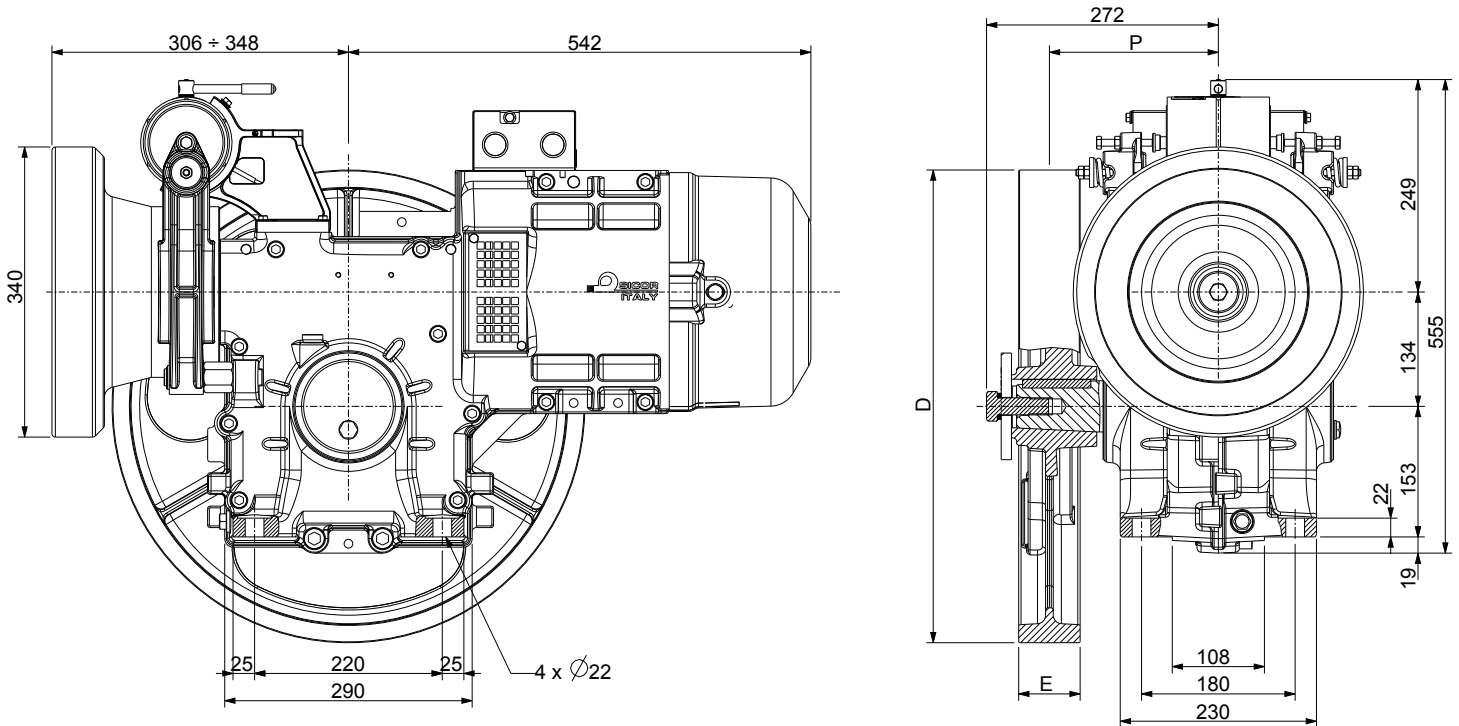

Wrapping System	Traction sheave		Dimension	Load*)	Static Load Direction	Brake Electromagnet		
	D [mm]	E [mm]				P [mm]	F [kN - kg]	[%]
ESW	340	116	210	22	100% ↓	24	5,25	126
	340	76	195	25,5 - 2600		48	2,30	110
	340	100	202	24,7 - 2500		60	1,77	106
CSW	400	70	197	25,5 - 2600	100% ↔ 100%	80	1,50	120
	450	70	197	25,5 - 2600		110	1,02	112
	480	70	197	25,5 - 2600		200	0,63	126
	550	70	197	25,5 - 2600				
	600	68	232	17,7 - 1800				

*) Max. static load on the slow shaft:
CSW: Conventional single wrap.
ESW: Extended single wrap (patented).

				50Hz				60Hz		
				VVVF 1500 rpm 4 Poles AC2 1500/375 rpm 4/16 Poles				VVVF 1800 rpm 4 Poles AC2 1800/450 rpm 4/16 Poles		
				Motor Output [kW]						
					VVVF/AC2 4	VVVF/AC2 5,5	VVVF 6,7		VVVF/AC2 4,4	VVVF/AC2 6
Wrapping system		R.R.	Traction Sheave Ø	Speed syn.	Max Rated Load			Speed syn.	Max Rated Load	
CSW	ESW	[i]	[mm]	[m/s]	[kg]	[kg]	[kg]	[m/s]	[kg]	[kg]
X	X	1/52	340	0,51	750	--	--	0,62	750	--
X	X	1/45	340	0,59	750	--	--	0,71	705	750
X	X	1/52	400	0,60	750	--	--	0,72	675	750
X	--	1/43	340	0,62	750	--	--	0,75	675	750
X	--	1/52	450	0,68	665	695	--	0,82	600	695
X	--	1/45	400	0,70	660	750	--	0,84	600	725
X	--	1/52	480	0,72	625	650	--	0,87	565	650
X	--	1/43	400	0,73	635	750	--	0,88	575	750
X	--	1/45	450	0,79	590	710	--	0,94	535	645
X	--	1/43	450	0,82	565	705	--	0,99	510	705
X	--	1/52	550	0,83	545	570	--	1,00	490	570
X	--	1/45	480	0,84	550	665	--	1,01	500	600
X	--	1/43	480	0,88	530	660	--	1,05	480	660
X	--	1/52	600	0,91	500	520	--	1,09	450	520
X	--	1/45	550	0,96	480	580	--	1,15	435	525
X	--	1/43	550	1,00	460	580	--	1,21	415	580
X	X	2/53	340	1,01	490	700	750	1,21	445	630
X	--	1/45	600	1,05	440	530	--	1,26	400	480
X	--	1/43	600	1,10	425	530	--	1,32	380	530
X	X	2/53	400	1,19	415	595	725	1,42	375	535
X	--	2/43	340	1,24	405	575	715	1,49	365	520
X	--	2/53	450	1,33	370	530	645	1,60	335	475
X	--	2/53	480	1,42	345	495	605	1,71	315	445
X	--	2/43	400	1,46	345	490	605	1,75	310	440
X	--	2/53	550	1,63	305	430	530	1,96	275	385
X	--	2/43	450	1,64	305	435	540	1,97	275	390
X	--	2/43	480	1,75	285	410	505	2,10	260	365
X	--	2/53	600	1,78	275	395	485	2,13	250	355
X	--	2/43	550	2,01	250	355	440	2,41	225	320
X	--	2/43	600	2,19	230	325	405	2,63	205	295

		50Hz			60Hz			
		Motor Output [kW]						
			VVVF/AC2 4	VVVF/AC2 5,5	VVVF 6,7		VVVF/AC2 4,4	VVVF/AC2 6
R.R.	Max Output Torque	Geared Efficiency			Max Output Torque	Geared Efficiency		
[i]	[Nm]				[Nm]			
1/52	963	0,73	0,76	0,77	963	0,72	0,75	
1/45	980	0,75	0,77	0,79	890	0,74	0,77	
1/43	978	0,75	0,78	0,79	978	0,74	0,77	
2/53	895	0,80	0,83	0,84	895	0,79	0,82	
2/43	856	0,82	0,84	0,86	856	0,80	0,83	

Rated load values listed in the table include the weight of the ropes. To know the theoretical load, subtract the weight of the ropes.
 Position Of The Geared = Top. Counterweight = 50%. Plant efficiency = 0,80

				50Hz			60Hz		
				VVVF 1000 rpm 6 Poles AC2 1000/375 rpm 6/16 Poles			VVVF 1200 rpm 6 Poles AC2 1200/450 rpm 6/16 Poles		
				Motor Output [kW]					
Wrapping system		R.R.	Traction Sheave Ø	Speed syn.	Max Rated Load		Speed syn.	Max Rated Load	
CSW	ESW	[i]	[mm]	[m/s]	[kg]	[kg]	[m/s]	[kg]	
X	X	1/52	340	0,34	750	--	0,41	750	
X	X	1/45	340	0,40	750	--	0,47	750	
X	X	1/52	400	0,40	750	--	0,48	750	
X	--	1/43	340	0,41	750	--	0,50	750	
X	--	1/52	450	0,45	675	750	0,54	750	
X	--	1/45	400	0,47	670	750	0,56	750	
X	--	1/52	480	0,48	630	745	0,58	745	
X	--	1/43	400	0,49	645	750	0,58	750	
X	--	1/45	450	0,52	595	750	0,63	750	
X	--	1/43	450	0,55	575	750	0,66	725	
X	--	1/52	550	0,55	550	650	0,66	650	
X	--	1/45	480	0,56	560	730	0,67	705	
X	--	1/43	480	0,58	535	740	0,70	680	
X	--	1/52	600	0,60	505	595	0,72	595	
X	--	1/45	550	0,64	490	640	0,77	615	
X	--	1/43	550	0,67	470	645	0,80	590	
X	X	2/53	340	0,67	495	685	0,81	630	
X	--	1/45	600	0,70	445	585	0,84	565	
X	--	1/43	600	0,73	430	590	0,88	545	
X	X	2/53	400	0,79	420	580	0,95	535	
X	--	2/43	340	0,83	410	565	0,99	520	
X	--	2/53	450	0,89	375	515	1,07	475	
X	--	2/53	480	0,95	350	485	1,14	445	
X	--	2/43	400	0,97	350	480	1,17	440	
X	--	2/53	550	1,09	305	420	1,30	385	
X	--	2/43	450	1,10	310	425	1,32	390	
X	--	2/43	480	1,17	290	400	1,40	365	
X	--	2/53	600	1,19	280	385	1,42	355	
X	--	2/43	550	1,34	255	350	1,61	320	
X	--	2/43	600	1,46	230	320	1,75	295	

		50Hz		60Hz	
		Motor Output [kW]			
		VVVF/AC2 2,7	VVVF/AC2 3,6	VVVF/AC2 4	VVVF/AC2 4
R.R.	Max Output Torque	Geared Efficiency		Max Output Torque	Geared Efficiency
[i]	[Nm]			[Nm]	
1/52	1102	0,73	0,75	1102	0,75
1/45	1080	0,75	0,77	1080	0,77
1/43	1102	0,75	0,78	1102	0,77
2/53	1036	0,80	0,83	1036	0,82
2/43	992	0,82	0,84	992	0,83

		50Hz								
		VVVF 1500 rpm 4 Poles AC2 1500/375 rpm 4/16 Poles				VVVF 1000 rpm 6 Poles AC2 1000/375 rpm 6/16 Poles				
		Asynchronous Rated Power [kW]								
		VVVF 4	VVVF 5,5	VVVF 6,7	AC2 4	AC2 5,5	VVVF 2,7	VVVF 3,6	AC2 2,7	AC2 3,6
		Motor Parameters								
Rated Voltage (star connection) ⁽¹⁾⁽³⁾	[V]	400	400	400	400	400	400	400	400	400
Frequency	[Hz]	50	50	50	50	50	50	50	50	50
Synchronous Speed	[rpm]	1500	1500	1500	1500/375	1500/375	1000	1000	1000/375	1000/375
Asynchronous Speed	[rpm]	1379	1368	1440	1359/276	1359/280	912	920	893/268	917/270
Rated Current ⁽²⁾	[A]	10,4	15,2	16,5	12,7/11,4	15/15,5	8,8	11,5	10,9/11,5	15/12,4
Rated Torque	[Nm]	27,7	38,4	44,4	28,1	38,7	28,3	37,5	28,9	37,2
Cos φ Power Factor	[]	0,72	0,69	0,69	0,77	0,69	0,6	0,67	0,65	0,5
Starting Current	[A]	42	58	95	39	52	29	38	29	39
Starting Torque	[Nm]	73	114	115	79	94	77	111	69	98
Duty Cycle	[%]	40	40	40	30+10	30+10	40	40	30+10	30+10
Starts per Hour	[s/h]	240	240	240	180	180	240	240	180	180
Insulation Class	[]	F	F	F	F	F	F	F	F	F
Degree of Protection IP	[]	IP21	IP21	IP21	IP21	IP21	IP21	IP21	IP21	IP21
Phase Resistance 4/6 poles at 20°C	R _{4/6} [Ω]	1,4	0,88	--	1,5	1,2	1,9	1,3	2,1	1,4
Phase Resistance 16 poles at 20°C	R ₁₆ [Ω]	--	--	--	7,5	4	--	--	5,6	4,8

(1) The motors are standard supplied with star connection (Y), the customer can arrange a delta connection (Δ).

(2) The indicated current values are related to 400V voltage. For current values with delta connection, multiply the values by 1,732.

(3) The standard supply voltage is suitable for 380-400V/220-230V power supplies.

The geared machine includes a fan, 1~220...240V, 50/60Hz, 0,7A.

Available on request 115V supply voltage.

The inertia value includes the high speed shaft, while the flywheel is excluded.

		60Hz					
		VVVF 1800 rpm 4 Poles AC2 1800/450 rpm 4/16 Poles			VVVF 1200 rpm 6 Poles AC2 1200/450 rpm 6/16 Poles		
		Asynchronous Rated Power [kW]					
		VVVF 4,4	VVVF 6	AC2 4,4	AC2 6	VVVF 4	AC2 4
		Motor Parameters					
Rated Voltage (star connection) ⁽¹⁾⁽³⁾	[V]	380	400	400	400	400	380
Frequency	[Hz]	60	60	60	60	60	60
Synchronous Speed	[rpm]	1800	1800	1800/450	1800/450	1200	1200/450
Asynchronous Speed	[rpm]	1630	1660	1606/330	1680/380	1100	1096/318
Rated Current ⁽²⁾	[A]	11	15,2	11,8/10	18/14	20	13,2/10,4
Rated Torque	[Nm]	25,8	34,5	26,2	34,1	34,7	34,8
Cos φ Power Factor	[]	0,81	0,81	0,63	0,78	0,67	0,58
Starting Current	[A]	42	52	39	48	42	35
Starting Torque	[Nm]	65	113	64	74	73	57
Duty Cycle	[%]	40	40	30+10	30+10	40	30+10
Starts per Hour	[s/h]	240	240	180	180	240	180
Insulation Class	[]	F	F	F	F	F	F
Degree of Protection IP	[]	IP21	IP21	IP21	IP21	IP21	IP21
Phase Resistance 4/6 poles at 20°C	R _{4/6} [Ω]	0,98	0,57	--	0,9	1,62	--
Phase Resistance 16 poles at 20°C	R ₁₆ [Ω]	--	--	--	--	--	--

(1) The motors are standard supplied with star connection (Y), the customer can arrange a delta connection (Δ).

(2) The indicated current values are related to 400V voltage. For current values with delta connection, multiply the values by 1,732.

(3) The standard supply voltage is suitable for 380-400V/220-230V power supplies.

The geared machine includes a fan, 1~220...240V, 50/60Hz, 0,7A.

Available on request 115V supply voltage.

The inertia value includes the high speed shaft, while the flywheel is excluded.

TRACTION SHEAVES AND GROOVES NUMBER x ROPES DIAMETER

Winding System	Traction sheave		Max n° Grooves x D	Grooves Pitch
	D [mm]	E [mm]	n° x mm	l [mm]
ESW	340	116	6xD8	20
	340	76	6xD8	12
	340	100	8xD8	12
	400	70	5xD8	14
	400	70	4xD9	17
	400	70	4xD10	17
	450	70	5xD8	14
	450	70	4xD9	17
	450	70	4xD10	17
	450	70	4xD11	17
	480	70	4xD11	17
	480	70	3xD12	19
CSW	550	70	5xD8	14
	550	70	4xD9	17
	550	70	4xD10	17
	550	70	4xD11	17
	550	70	3xD12	19
	550	70	3xD13	19
	600	68	5xD8	12
	600	68	4xD9	16
	600	68	4xD10	16
	600	68	3xD11	18
	600	68	3xD12	18
	600	68	3xD13	19

VCI

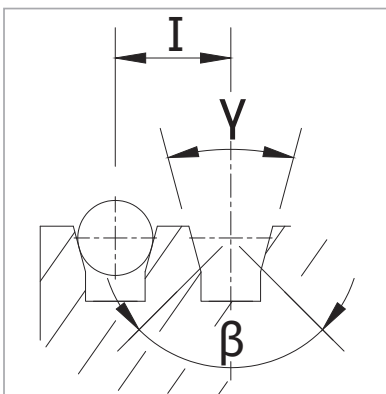

V grooves with undercut

UCI

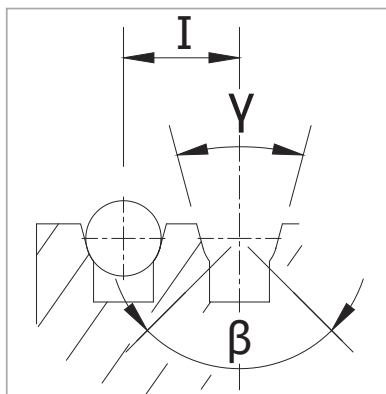

U grooves with undercut

γ = groove angle
 β = undercut angle
 I = grooves pitch

BEDPLATE | TOP MACHINE WITHOUT DIVERTING PULLEY FOR CSW WRAPPING

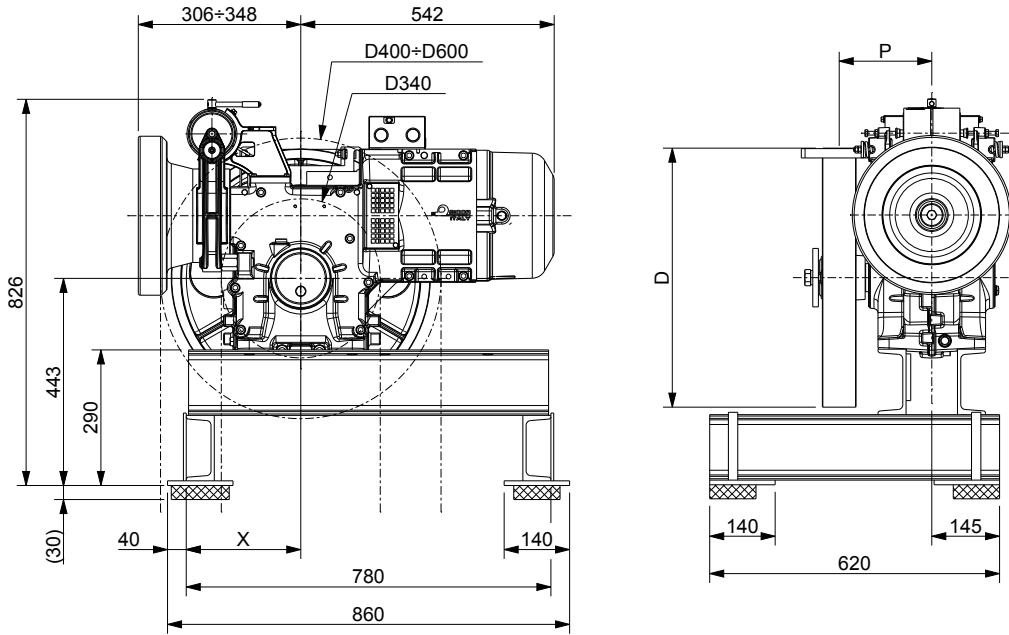

Code	Traction Sheave	P	X
	D [mm]	[mm]	[mm]
XTE0053 (included vibration dampers)	340	195	245
	340	202	245
	400	197	180
	450	197	180
	480	197	180
	550	197	245
	600	232	245

Weight of machine bedplate: 60 kg (bedplate + vibration dampers)

INSTALLATION POSITION

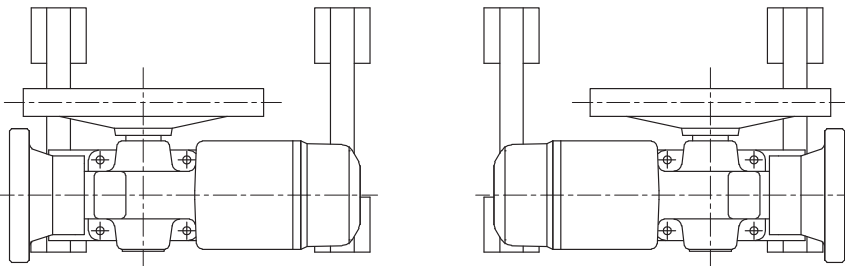

Right hand Machine

Left hand Machine

VIBRATIONS DAMPER SET UP

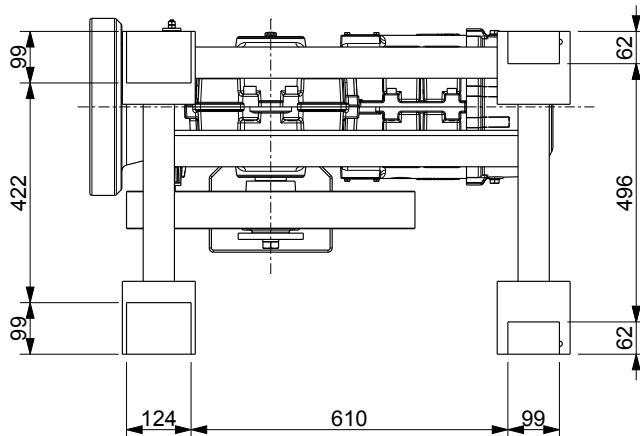

Damper code	Dimension
	[mm]
TAI0033	62x99xh30
TAI0017	99x124xh30

BEDPLATE | TOP MACHINE WITH DIVERTING PULLEY FOR CSW WRAPPING

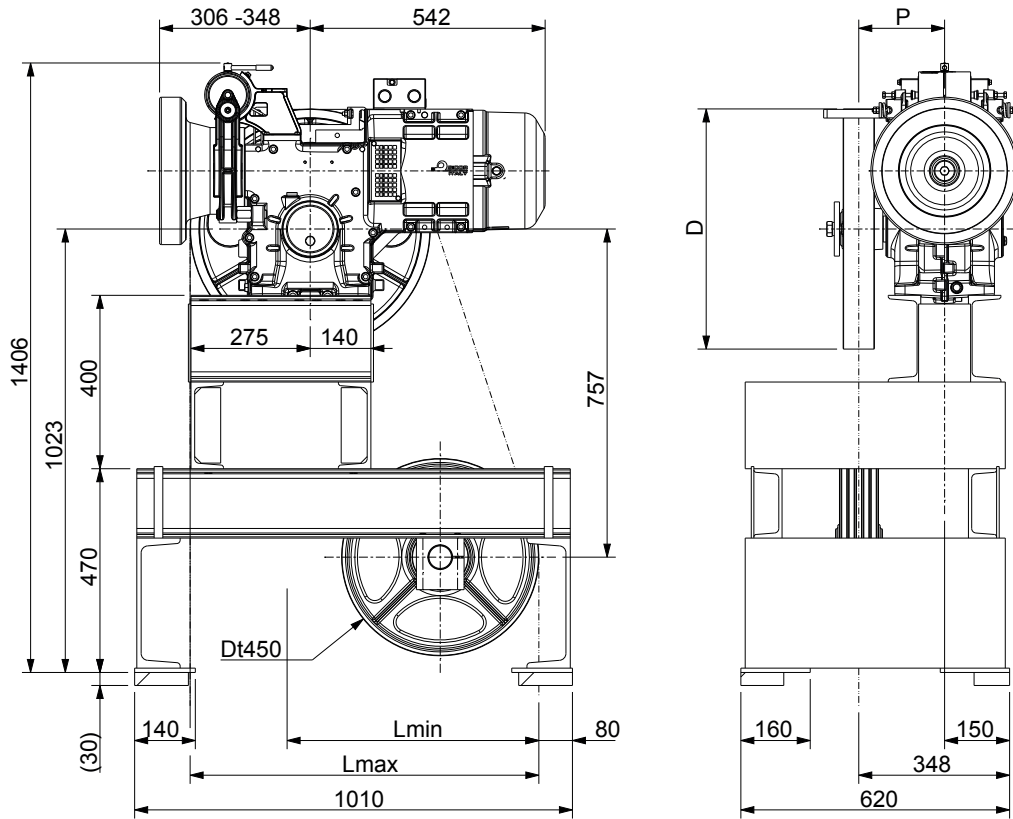

Code	Traction Sheave	P	L min	L max	Ø Div. Pulley shaft
	D [mm]	[mm]	[mm]	[mm]	[mm]
XTE0056	450	197 - 201	520	850	55
	480	202	--		
	550	197 - 204	--		
	600	232	--		

Weight of machine bedplate: 195 kg. (bedplate + diverting pulley Dt450 + vibration dampers)

INSTALLATION POSITION

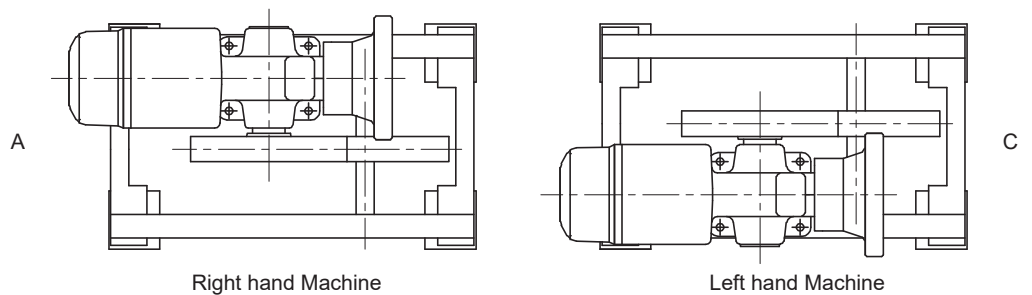

VIBRATIONS DAMPER SET UP

Damper code	Dimension
	[mm]
TAI0016	82x124xh30
TAI0017	99x124xh30

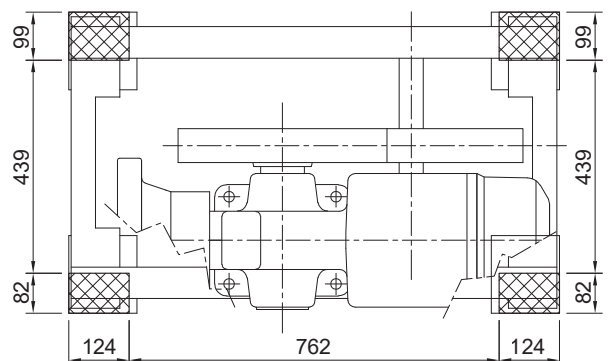

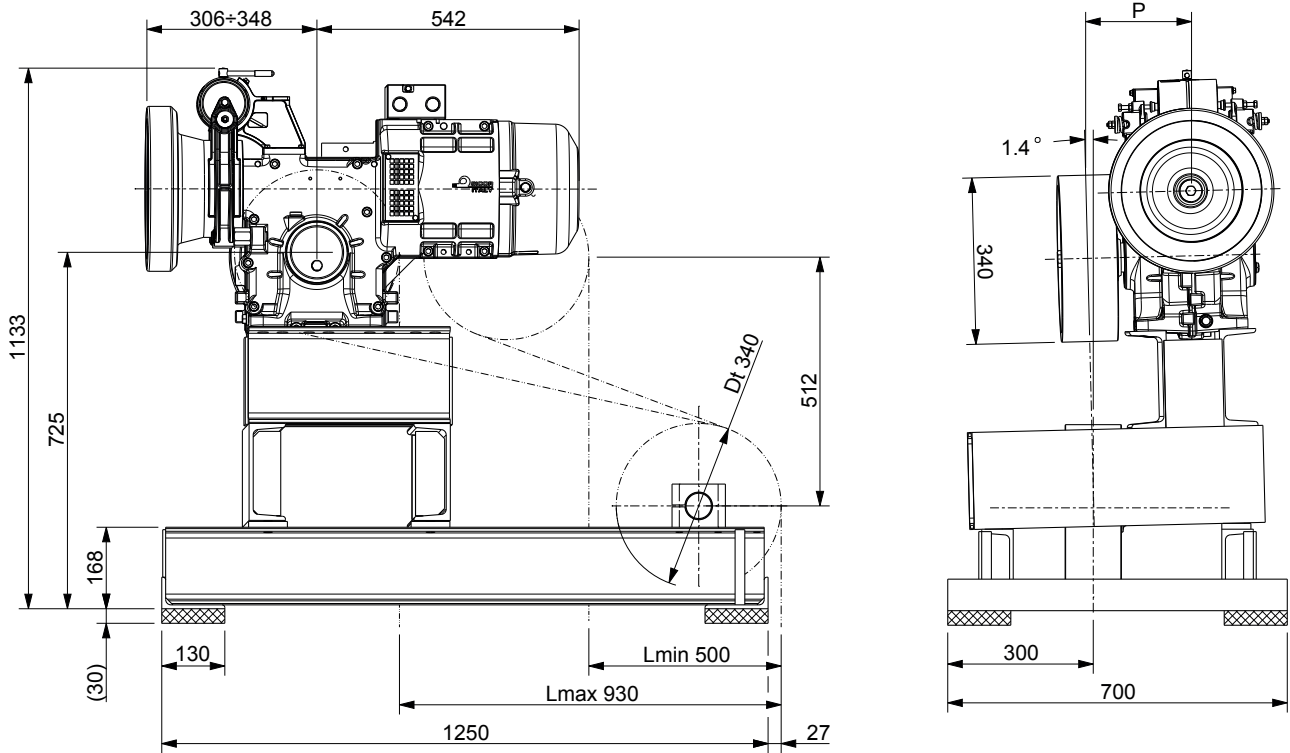

XTE0057 (included vibration dampers)
 Weight of machine bedplate: 150 kg
 (bedplate + diverting pulley Dt340 + vibration dampers)

INSTALLATION POSITION

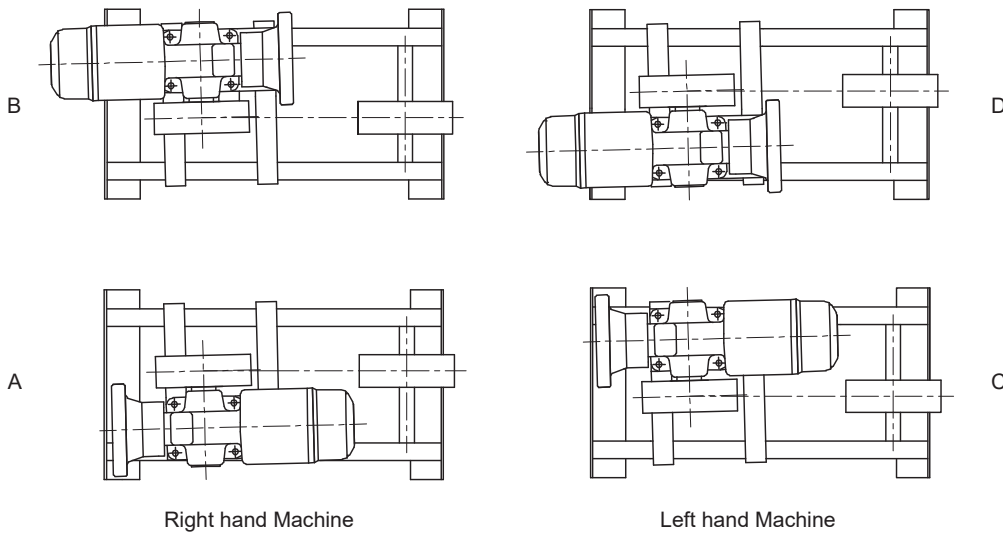

Right hand Machine

Left hand Machine

BEDPLATE | MACHINE FOR SIDE DRIVE LIFT WITH Dt 340 DIVERTING PULLEY

Roping 1:1

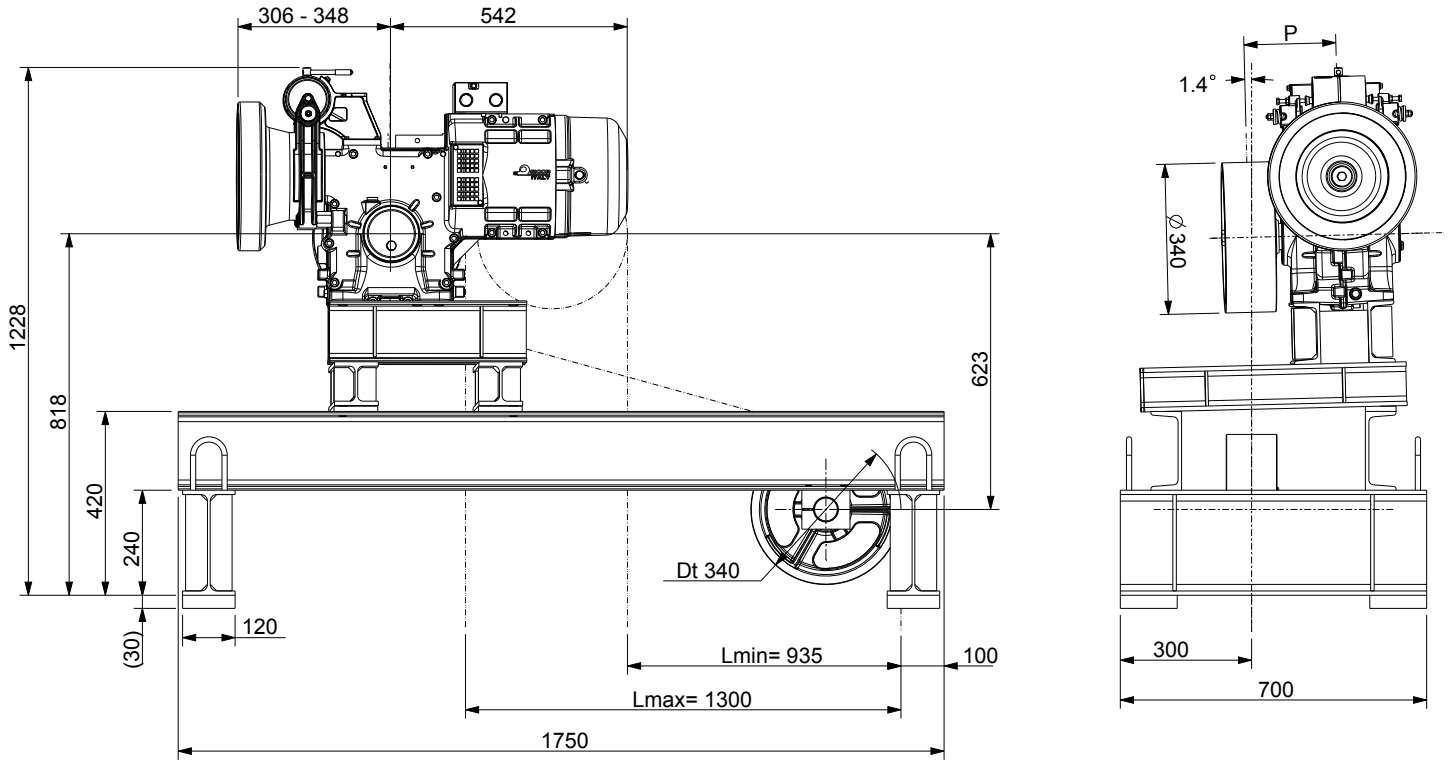

XTE0058 (included vibration dampers)
 Weight of machine bedplate: 160 kg
 (bedplate + diverting pulley Dt340 + vibration dampers)

INSTALLATION POSITION

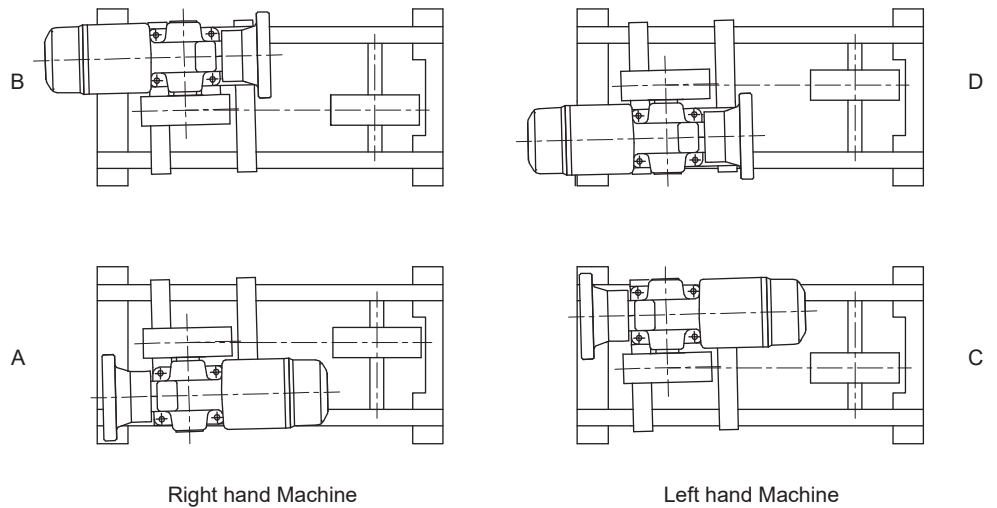

Right hand Machine

Left hand Machine

DIVERTING PULLEYS AND GROOVES NUMBER x ROPES DIAMETER

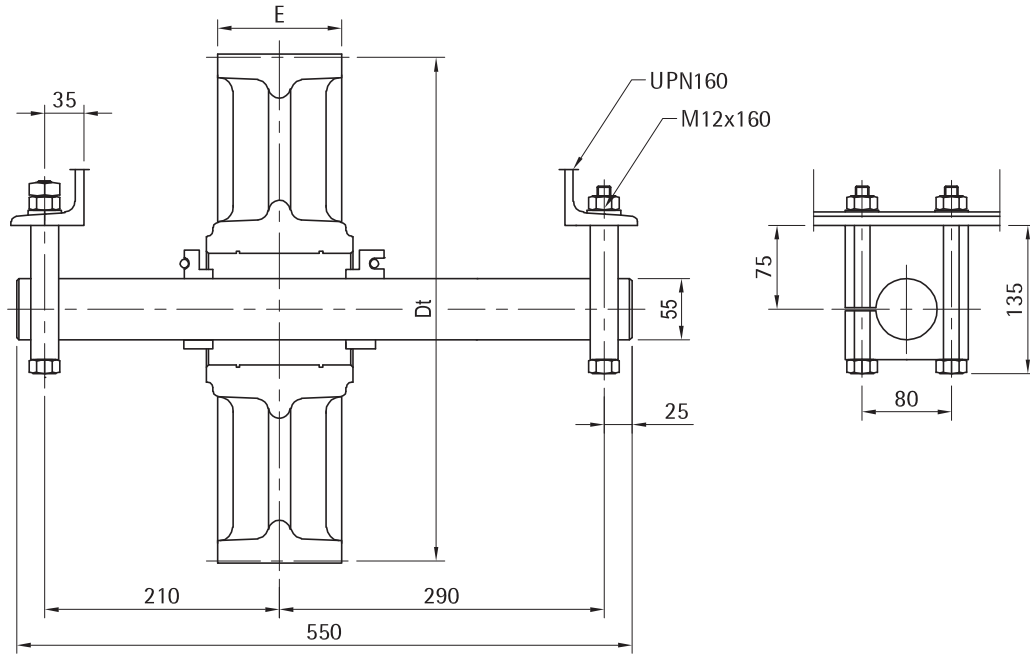

Diverting Pulley		Max n° Grooves x D	Grooves Pitch
Dt [mm]	E [mm]	n° x mm	l [mm]
340	80	6xD8	12
	120	6xD8	20
		8xD8	12/14
450	74	6xD8	12/14
	90	5xD11	17
		4xD11	17
		4xD12	19
530	90	3xD13	19



Sicor S.R.L.

Viale Caproni, 32 Rovereto (TN) - Italy • Tel: +39 0464 484 111 • info@sicoritaly.com

www.sicoritaly.com